



**DEPARTMENT OF MECHANICAL ENGINEERING**  
**GOVT. POLYTECHNIC, BALASORE**

---

**LAB MANUAL**  
**TOM (Pr.1)**  
**4<sup>TH</sup> SEMESTER**



**GOVT. POLYTECHNIC, BALASORE**

## GENERAL LABORATORY INSTRUCTIONS

- You should be punctual for your laboratory session and should not leave the lab without the permission of the teacher.
- Each student is expected to have his/her own lab book where they will take notes on the experiments as they are completed.
- The lab books will be checked at the end of each lab session. Lab notes are a primary source from which you will write your lab reports.
- You and your batch mates will work closely on the experiments together. One partner doing all the work will not be tolerated. All the Batch mates should be able to explain the purpose of the experiment and the underlying concepts.
- Please report immediately to the member of staff or lab assistant present in the laboratory; if any equipment is faulty.

:

:

## **ORGANIZATION OF THE LABORATORY**

- It is important that the experiments are done according to the timetable and completed within the scheduled time.
- You should complete the pre lab work in advance and utilize the Laboratory time for verification only.
- The aim of these exercises is to develop your ability to understand, analyze and test them in the laboratory.
- A member of staff and a Lab assistant will be available during Scheduled laboratory sessions to provide assistance.
- Always attempt experiments; first without seeking help.
- When you get into difficulty; ask for assistance.

## **ASSESSMENT**

- The laboratory work of a student will be evaluated continuously during the semester for 25 marks. Of the 25 marks, 15 marks will be awarded for day-to-day work.
- For each experiment marks are awarded under three heads:
  - Pre lab preparation - 5 marks
  - Practical work - 5marks, and
  - Record of the Experiment - 5marks
- Internal lab test(s) conducted during the semester carries 10 marks.
- End semester lab examination, conducted as per the JNTU regulations, carries 50 marks.
- At the end of each laboratory session you must obtain the signature of the teacher along with the marks for the session out of 10 on the lab notebook.

## **LAB REPORTS**

- Note that, although students are encouraged to collaborate during lab, each must individually prepare a report and submit.
- They must be organized, neat and legible.
- Your report should be complete, thorough, understandable and literate.
- You should include a well-drawn and schematic for each experiments Investigated.
- Your reports should follow the prescribed format, to give your report structure and to make sure that you address all of the important points.
- Graphics requiring- drawn straight lines should be done with a straight edge. Well drawn freehand sketches are permissible for schematics.
- Space must be provided in the flow of your discussion for any tables or figures. Do not collect figures and drawings in a single appendix at the end of the report.
- Reports should be submitted within one week after completing a scheduled lab session.

## **PRESENTATION**

- Experimental facts should always be given in the past tense.
- Discussions or remarks about the presentation of data should mainly be in the present tense.
- Discussion of results can be in both the present and past tenses, shifting back and forth from experimental facts to the presentation.
- Any specific conclusions or deductions should be expressed in the past tense.

## **REPORT FORMAT**

### **Lab write ups should consist of the following sections:**

- **Aim:** A concise statement describing the experiment and the results. This is usually not more than 3 sentences. Since the abstract is a summary of what you have done, it's a good idea to write this last.
- **Apparatus:** Describe what equipment and components you used to conduct the experiment.
- **Theory:** Several paragraphs that explain the motivation of the experiment. Usually in this statement you state what you intent to accomplish as well as the expected results of the experiment.
- **Procedure:** Describe how you conducted the experiment.
- **Results and Analysis:** This is the main body of the report. Graphs, tables, schematics, diagrams should all be included and explained. Results of any calculations should be explained and shown. State the results of the experiment. Include any problems encountered.
- **Conclusion:** Explain how the experiment went, and whether you were able to achieve the expected results stated in the introduction.

### **General Rules:**

1. Lab Access: Only authorized personnel should have access to the lab.
2. Attire: Wear appropriate lab attire, including safety goggles, closed-toe shoes, and lab coats.
3. No Food or Drinks: Eating, drinking, and chewing gum should be prohibited inside the lab area.
4. Equipment Use: Use equipment only if you are trained and authorized to do so.
5. Follow Procedures: Adhere strictly to the established lab procedures and protocols.
6. Safety Equipment: Know the locations of safety showers, eyewash stations, fire extinguishers, and first aid kits.
7. Report Incidents: Immediately report accidents, spills, or any equipment malfunction to the lab supervisor.

### **Mechanical Lab Precautions:**

1. Tool Safety: Handle tools and equipment with care. Return them to their designated places after use.
2. Machine Safety: Follow proper procedures while operating machinery to prevent accidents.
3. Protective Gear: Wear appropriate personal protective equipment (PPE) such as gloves, helmets, or masks based on the task being performed.
4. Ventilation: Ensure adequate ventilation in the lab, especially when working with materials that produce fumes or gases.
5. Chemical Handling: Handle chemicals cautiously, following recommended storage, usage, and disposal guidelines.
6. Electrical Safety: Be aware of electrical hazards and use insulation, grounding, and proper wiring when working with electrical components.

### **Additional Safety Measures:**

1. Emergency Procedures: Understand evacuation plans and emergency procedures in case of fire, chemical spills, or other emergencies.
2. Labeling: Clearly label all containers with the contents, date, and any hazards they pose.
3. Workspace Cleanliness: Keep workspaces tidy to minimize potential hazards and allow for clear movement.
4. No Unauthorized Experiments: Avoid conducting experiments without proper approval or supervision.

### **Protocols for Specific Experiments:**

1. Risk Assessment: Conduct a thorough risk assessment before starting any experiment and implement necessary safety measures.
2. Supervision: Ensure experiments are supervised by experienced personnel, especially when dealing with high-risk procedures or equipment.

# EXPERIMENT NO: 01

## GOVERNOR

**AIM:** To Determine the centrifugal force of watt/Porter/ Proell /hartnell Governor

### THEORY:

The function of a governor is to regulate the mean speed of an engine, when there are variations in the load e.g. when the load on an engine increases, its speed decreases, therefore it becomes necessary to increase the supply of working fluid. If the load on the engine decreases, its speed increases and thus less working fluid is required. The governor automatically controls the supply of working fluid to the engine with the varying load conditions and keeps the mean speed within certain limits.

The governors may, broadly, be classified as:

1. Centrifugal governor
2. Inertia governor

The centrifugal governors may further be classified as follows:

1. pendulum type (watt governor)
2. Loaded type i. Dead weight governor (Porter and Proell governor)  
ii. Spring controlled governors (Hartnell governor, Hartung governor, Wilson Hartnell governor and Pickering governor)

### Centrifugal Governor

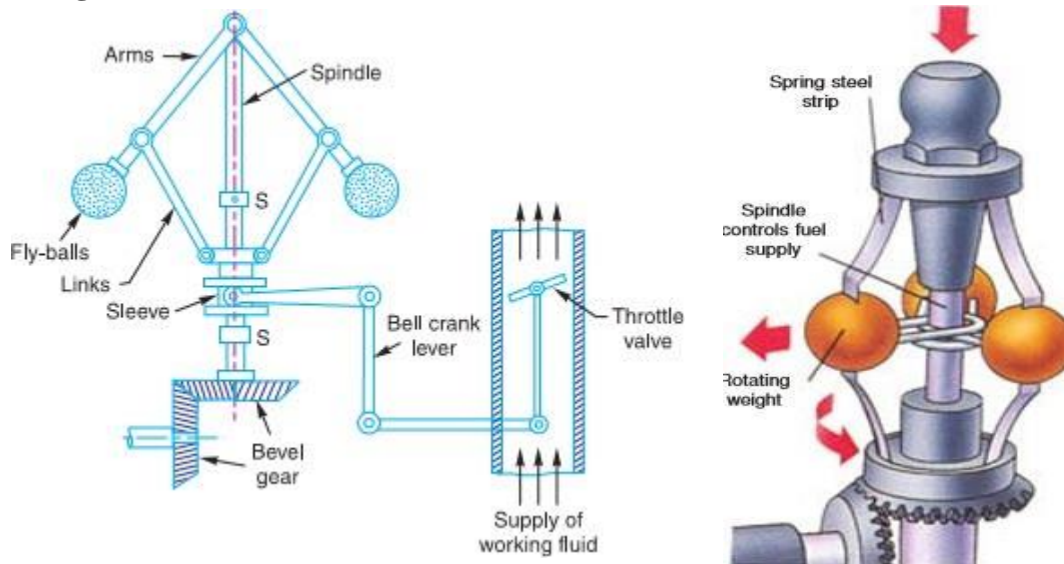

Fig 1.

The centrifugal governors are based on the balancing of centrifugal force on the rotating balls by an equal and opposite radial force, known as the controlling force. It consists of two balls of equal mass, which are attached to the arms as shown in Fig 1. These balls are known as governor balls or fly balls. The balls revolve with a spindle, which is driven by the engine through bevel gears. The upper ends of the arms are pivoted to the spindle, so that the balls may rise up or fall down as they revolve about the vertical axis. The arms are connected by the links to a sleeve, which is keyed to the spindle. This sleeve revolves with the spindle; but can slide up and down. The balls and the sleeve rise when the spindle speed increases, and falls when the speed decreases. In order to limit the travel of the sleeve in upward and downward directions, two stops S, S are provided on the spindle. The sleeve is connected by a bell crank lever to a throttle valve. The supply of the working fluid decreases when the sleeve rises and increases when it falls.

When the load on the engine increases, the engine and the governor speed decreases. This results in the decrease of centrifugal force on the balls. Hence the balls move inwards and the sleeve moves downwards. The downward movement of the sleeve operates a throttle valve at the other end of the bell crank lever to increase the supply of working fluid and thus the engine speed is increased. In this case, the extra power output is provided to balance the increased load. When the load on the engine decreases, the engine and the governor speed increases, which results in the increase of centrifugal force on the balls. Thus the balls move outwards and the sleeve rises upwards. This upward movement of the sleeve reduces the supply of the working fluid and hence the speed is decreased. In this case, the power output is reduced.

## **PROCEDURE:**

Mount the required governor assembly over the spindle.

1. Tighten the necessary bolts.
2. Start the motor and gradually increase the speed.
3. The flyweight will fly outward due to which the sleeve will rise.
4. Note down the speed and sleeve rise or calculate by theoretical method.
5. Repeat the experiment at different speeds till the balls fly to maximum position.
6. Bring back the sleeve down by reducing the speed gradually and stop.

## **Specifications**

Watt & Porter Governor

Weight of Balls = ----- Kg

Initial height  $h_0$  = ----- mm

Length of the link  $L$  = ----- mm

### Proell Governor:

Length of the link  $L = \dots\dots\dots$  mm

Initial height  $h_0 = \dots\dots\dots$  mm

### Hartnell Governor

Initial height  $h_0 = \dots\dots\dots$  mm

Length of the link  $L = \dots\dots\dots$  mm

### TABULATION

| Sl.No | Sleeve lift<br>in cm | Rpm<br>N | Radius of<br>rotation | Centrifugal<br>force F |
|-------|----------------------|----------|-----------------------|------------------------|
|       |                      |          |                       |                        |
|       |                      |          |                       |                        |
|       |                      |          |                       |                        |
|       |                      |          |                       |                        |

$x =$  raise of sleeve in cm

$h_0 =$  initial height

$w =$  weight of balls

$L =$  length of the link

$$\omega = 2\pi N / 60$$

$N =$  Speed in rpm

Initial radius of rotation =  $r_1$

### CALCULATION

1. Height of balls where link centre lines intersect  $h = m$

$$h = \frac{h_0 + X}{2}$$

2. Initial radius of rotation =  $r_1$

$$r_1 = \sqrt{L^2 - h^2}$$

3.  $r = r_1 + 0.16$

4. Angular speed

$$\omega = \frac{2\pi N}{60}$$

5. Centrifugal force

$$F = \frac{w}{g} \times \omega^2 \times r$$



## PORTER GOVERNOR (WITH WEIGHT)

The Porter governor is a modification of a Watt's governor, with central load attached to the sleeve as shown in Fig 2. The load moves up and down the central spindle. This additional downward force increases the speed of revolution required to enable the balls to rise to any predetermined level.

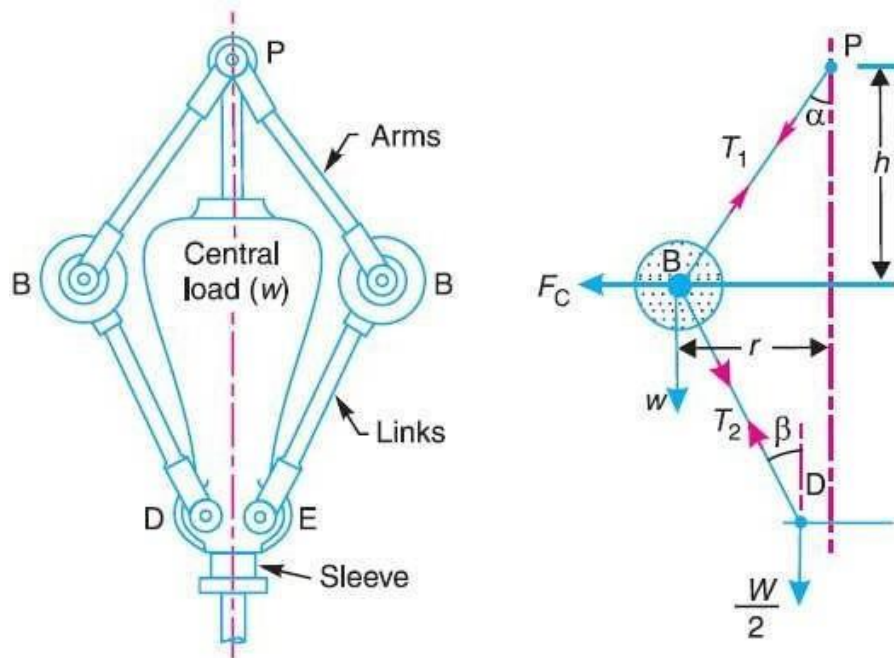

Porter governor.

Fig 2

## TABULATION

| SI No | LIFT X in mm | Speed in Rpm | h in m | r <sub>1</sub> in mm | r in mm | φ in rad/sec | Centrifugal force in Kgf |
|-------|--------------|--------------|--------|----------------------|---------|--------------|--------------------------|
|       |              |              |        |                      |         |              |                          |
|       |              |              |        |                      |         |              |                          |
|       |              |              |        |                      |         |              |                          |
|       |              |              |        |                      |         |              |                          |

## WATT GOVERNOR (WITHOUT WEIGHT)

The simplest form of a centrifugal governor is watt governor (Fig3). It is basically a conical pendulum with links attached to a sleeve of negligible mass. The arms of the governor may be connected to the spindle in the following three ways:

1. The pivot P may be on the spindle axis.
2. The pivot P may be offset from spindle axis and arms when produced intersect at O.
3. The pivot P may be offset but the arms cross the axis at O.

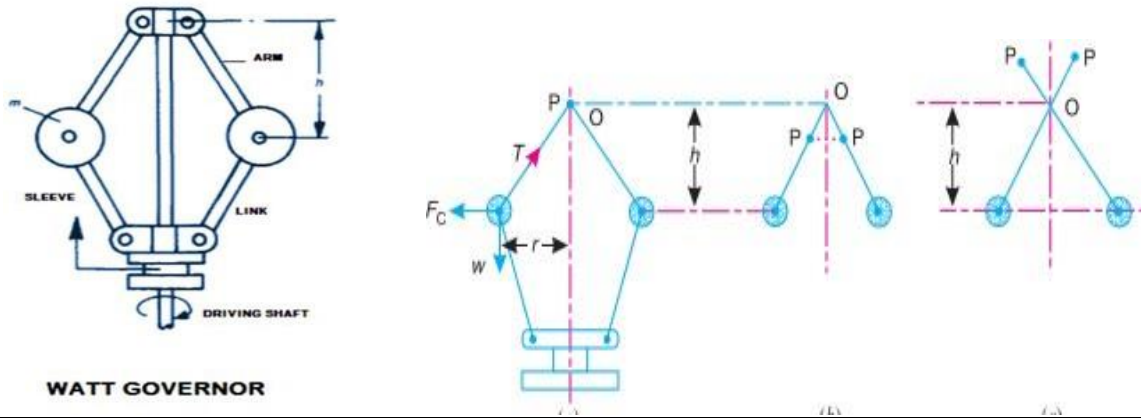

**WATT GOVERNOR**

Fig 3

**TABULATION**

| No | LIFT X in mm | Speed in Rpm | H in m | r <sub>1</sub> in mm | r in mm | ω in rad/sec | Centrifugal force in Kgf |
|----|--------------|--------------|--------|----------------------|---------|--------------|--------------------------|
|    |              |              |        |                      |         |              |                          |
|    |              |              |        |                      |         |              |                          |
|    |              |              |        |                      |         |              |                          |
|    |              |              |        |                      |         |              |                          |

**PROELL GOVERNOR**

The Proell governor has the balls fixed at B and C to the extension of the links DF and EG, as shown in Fig 4. The arms FP and GQ are pivoted at P and Q respectively.

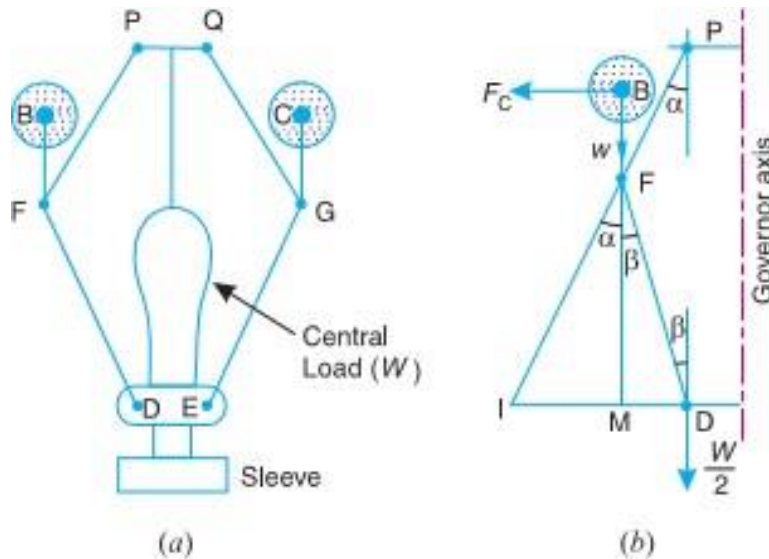

Fig 4

## TABULATION

| No | LIFT X in mm | Speed in Rpm | h in m | $r_1$ in mm | r in mm | $\phi$ in rad/sec | Centrifugal force in Kgf |
|----|--------------|--------------|--------|-------------|---------|-------------------|--------------------------|
|    |              |              |        |             |         |                   |                          |
|    |              |              |        |             |         |                   |                          |
|    |              |              |        |             |         |                   |                          |
|    |              |              |        |             |         |                   |                          |

## HARTNELL GOVERNOR

A Hartnell governor is a spring loaded governor as shown in Fig 5. It consists of two bell crank levers pivoted at the points O, O to the frame. The frame is attached to the governor spindle and therefore rotates with it. Each lever carries a ball at the end of the vertical arm OB and a roller at the end of the horizontal arm OR. A helical spring in compression provides equal downward forces on the two rollers through a collar on the sleeve. The spring force may be adjusted by screwing a nut up or down on the sleeve

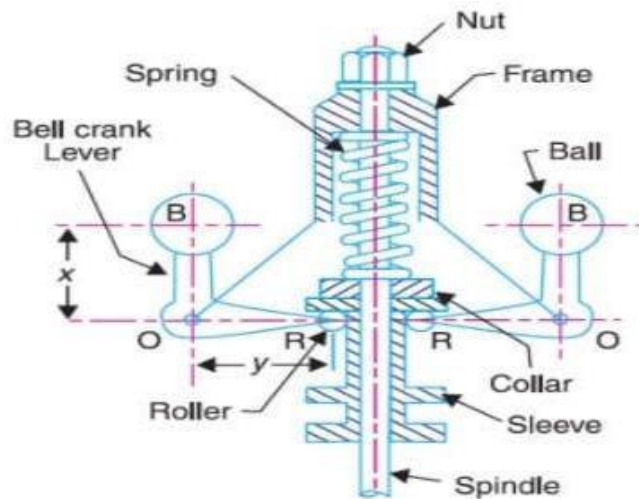

Fig 5

17

## TABULATION

| SI No | Lift X In m | Speed In Rpm | h In m | $r_1$ In m | $\phi$ In Rad/Sec | Centrifugal Force(Kgf) |
|-------|-------------|--------------|--------|------------|-------------------|------------------------|
|       |             |              |        |            |                   |                        |
|       |             |              |        |            |                   |                        |
|       |             |              |        |            |                   |                        |
|       |             |              |        |            |                   |                        |

**PRECAUTIONS:**

1. DO NOT KEEP THE MAINS ON when trial is complete increase the speed gradually.
2. Take the sleeve displacement reading when the pointer remains steady.
3. See that at higher speed the load on sleeve does not hit the upper sleeve of the governor.
4. while closing the test bring the dimmer to zero position and then switch OFF

**VIVA –QUESTIONS:**

1. What is the function of a governor?
2. How does it differ from that of a flywheel?
3. State the different types of governors.
4. What is the difference between centrifugal and inertia type governors ?
5. Explain the term height of the governor.
6. What are the limitations of a Watt governor?
7. What is the stability of a governor?
8. Define the Sensitiveness of governor.
9. Which of the governor is used to drive a gramophone?
10. The power of a governor is equal to

**RESULT:****CONCLUSION:**

## **EXPERIMENT NO 2**

### **STATIC AND DYNAMIC BALANCING**

#### **AIM**

To perform the experiment for static balancing and dynamic balancing

#### **APPARATUS USED**

Static and Dynamic Balancing m/c.

#### **THEORY: -**

##### **Static balancing**

A system of rotating masses is said to be in static balance if the combined mass centre of the system lies on the axis of rotation.

Whenever a certain mass is attached to a rotating shaft, it exerts some centrifugal force, whose effect is to bend the shaft and to produce vibrations in it. In order to prevent the effect of centrifugal force, another mass is attached to the opposite side of the shaft. The process of providing the second mass in order to counteract the effect of the centrifugal force of the first mass is called balancing of rotating masses.

##### **Dynamic balancing**

The masses are subjected to centrifugal forces when the shaft is rotating. Two conditions must be satisfied if the shaft is not to vibrate as it rotates:

- 1- There must be no out of balance centrifugal force trying to deflect the shaft.
- 2- There must be no out of balance moment or couple trying to twist the shaft.

If these conditions are not fulfilled, the shaft is not dynamically balanced.

#### **PROCEDURE:-**

Remove the belt, the value of weight for each block is determined by clamping each block in turn on the shaft and with the cord and container system suspended over the protractor disc, the number of steel balls, which are of equal weight are placed into one of the containers to exactly balance the blocks on the shaft. When the block becomes horizontal, the number of balls  $N$  will give the value of wt. for the block. For finding out  $W_r$  during static balancing proceed as follow:

1. Remove the belt.
2. Screw the combined hook to the pulley with groove. This pulley is diff. than the belt pulley.
3. Attached the cord end of the pans to above combined hook.
4. Attached the block no.-1 to the shaft at any convenient position and in vertical downward direction.
5. Put steel balls in one of the pans till the blocks starts moving up. (upto horizontal position).
6. Number of balls gives the  $W_r$  value of block-1. repeat this for 2-3 times and find the average no. of balls.
7. Repeat the procedure for other blocks.

For dynamic balancing put the Block in different planes and note down the data in the table

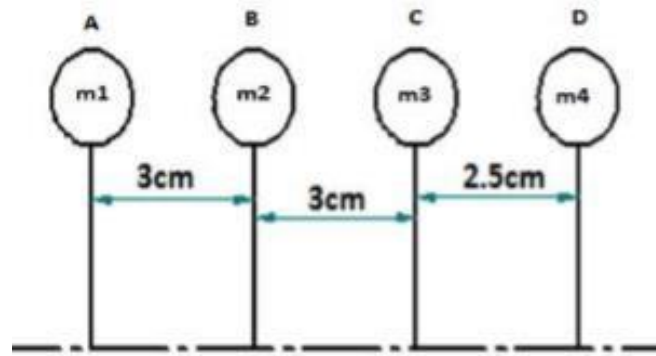

1. Consider one of the planes, say „A“ as the reference plane. The distance of all the other planes to the left of the reference plane may be regarded as negative, and those to the right as positive
2. Tabulate the data in the table shown below. The planes are tabulated in the same order in which they occur, reading from left to right. Since the magnitude of the centrifugal forces are proportional to the product of the mass and its radius, the product „ $mr^2$ “ can be calculated and tabulated.
3. Now draw the couple polygon considering the value of couple for each plane. Since the angular distance between masses is not given, consider position of mass 2 as horizontal, i.e. angle is zero. The value of couple for reference plane is zero. By drawing the couple polygon angular position of mass 3 and mass 4 with respect to mass 2 can be found out.
4. Now draw the force polygon considering the value of centrifugal force and angular positions of masses 2, 3 & 4. From the force polygon weight of mass 1 and its angular position can be found out
5. Considering the values of angular positions of masses, fix them on the shaft of the apparatus and check for static and dynamic balance.

#### TABULATION

| Sl.no | Plane | Radius(r)<br>In m | Centrifugal force $\div \omega^2$<br>$mr$<br>(kgm) | Distance from<br>plane X<br>(L in m) | Couple $\div \omega^2$<br>$mr^2$<br>(kg m <sup>2</sup> ) |
|-------|-------|-------------------|--|--------------------------------------|--|
|       |       |                   |  |                                      |  |
|       |       |                   |  |                                      |  |
|       |       |                   |  |                                      |  |
|       |       |                   |  |                                      |  |

#### RESULT:

#### CONCLUSION:

#### PRECAUTIONS:-

1. Couple should be represented by a vector drawn perpendicular to the plane of the couple.
2. Angular position measure carefully in clockwise direction.
3. Vector diagram should be represent with suitable scale.

## **EXPERIMENT NO 03**

### **JOURNAL BEARING APPARATUS**

#### **AIM**

To determine the present distribution of lubricating oil at various load and speed of a Journal Bearing.

#### **INTRODUCTION**

Journal Bearing Apparatus is designed on the bearing action used in practice. To formulate the bearing action accurately in mathematical terms is a more complex job. However, one can visualize the pattern of bearing pressure distribution due to the hydrodynamic action with the help of experimental rig. This helps to understand the subject properly.

The experimental rig consists of a small journal bearing as shown in Fig. This apparatus helps to demonstrate and study the effect of important variables such as speed, viscosity and load, on the pressure distribution in a Journal Bearing.

#### **DESCRIPTION**

The apparatus is illustrated in fig. It consists of a Brass bearing mounted freely on steel Journal shaft (A). This journal shaft is fixed directly on to a motor shaft (S). A Dimmer stat finely controls the speed of the DC motor. The Journal Bearing (E) has twelve (No.1 to 12) equispaced of  $30^{\circ}$  pressure tapings around its circumference, and two No, 13,14 additional **axial** pressure tapings are positioned on the topside of the journal bearing. The two sides of bearing are closed with two MS plates and sealed with gasket packing to avoid leakage. Balancing weights are provided to maintain the bearing in horizontal position while taking the readings. Both the weights can be adjusted freely along the rod.

Oil film pressures are indicated in 14-tubes manometer frame and readings directly in head of oil. Clear flexible tubes are fixed on the manometer frame and connected to the tapings spaced around bearing and thus permit the bearing to turn freely. The oil reservoir can be adjusted at required height and is

connected to the bearing by a flexible plastic tube. From this reservoir oil enters the bearing through this plastic tube.

### **SPECIFICATIONS**

- Diameter of Journal =  $2r = 52.5$  mm.
- Diameter of bearing =  $2R=50$ mm (with 12 radial tapings and 2 axial tapings).
- Bearing width (L) = 90mm.
- Motor speed = 800 -1000rpm (variable speed – DC).
- Motor control. Electronic DC Controller for motor speed control.
- Manometer frame with 14 tubes of 240cm. Height with scales and adjustable oil supply tank.
- Recommended oil = Lubricating oil SAE 30.
- Supply required AC single phase 230v.50Hz stabilized.
- $r$  = Radius of Journal.
- $\delta$  = Radial clearance ( $R-r$ ) =  $(52.5-50) = 2.5$  mm.
- $e$  = Eccentricity 00' between the center of the bearing & center of journal 2.5mm.
- Eccentricity ratio =  $e/ \delta$  or  $e=n \delta = 2.5/2.5 = 1$
- $\mu$  = Viscosity of oil.
- $R$  = Radius of journal bearing.
- $\theta$  = Angle between the one of center and the position of which is to measured.
- $h$  = Film thickness =2.5 mm

### **THEORY OF JOURNAL BEARINGS**

The mathematical analysis of the behavior of a journal in a bearing falls into two distinct categories:

1. Hydrodynamics of fluid flow between plates.
2. Journal bearing analysis where the motion of the journal in the oil films is considered.

According to the equation the Somerfield pressure function (when the velocity of the eccentricity and the whirl speed of the journal are both zero) is given by:

$$S_o = \left( \frac{r}{c} \right)^2 \left( \frac{\mu N}{P} \right) K_w \times 10^{-6}$$



when KW correction factor for side leakage from graph.

Where 'p' is the pressure of the oil film at the point measured anticlockwise from the line of common centers (00')

NOTE: Some books on lubrication give the Sommerfield function with a negative sign for 'n'. This is true if it is measured from the point of minimum thickness of the oil film.

### **RANGE OF EXPERIMENTS:**

Determine the pressure distribution in the oil film of the bearing for various speeds and

- a. Plot the polar pressure curve for various speeds by graphical method.
- b. Calculate by using the Sommerfield pressure equation for each speed.

$$S_o = \left( \frac{r}{c} \right)^2 \left( \frac{\mu N}{P} \right) K_w \times 10^{-6}$$

### **EXPERIMENTAL PROCEDURE:**

1. Fill the oil tank by using SAE 30 lubricating oil under test and position the tank at the desired height (**up to 1.5 liter oil**).
2. Drain out the air from the tubes on the manometer by removing the tubes from manometer.
3. Check that some oil sea page is there (Sea page of oil is necessary for cooling purpose).
4. Check the direction of rotation and increase the speed of the motor slowly.
5. Set the speed and let the journal run for about an 2 minutes until the oil in the bearing is warmed up and check the steady oil levels at various tapings.
6. Add the required loads and adjust the balancing weights, on the rod to maintain the horizontal levels position.
7. When the manometer levels are settled down, take the pressure readings on 1-14 manometer tubes. For circumferential and axial pressure distribution.
8. Repeat the experiment for various speed and loads.
9. After the test is over set dimmer to zero position and switch off the main supply.
10. Keep the oil tank at lower most position so that there will be no leakage in the idle period.

## GRAPHS:

Graph to be plotted for pressure head of oil above supply head in cm of oil, at angular intervals of  $30^\circ$  of the oil film. The angular interval positions are measured in anticlockwise, commencing with position marked.

## SAMPLE OF CALCULATIONS TO FIND SOMMERFIELD

### EQUATION TABLE OF READINGS

| Tube No. | LOAD in Kg | Speed | Supply head in mm of oil, Ps | Pressure at different points, Pa | Actual pressure (Ps-Pa) |
|----------|------------|-------|------------------------------|----------------------------------|-------------------------|
| 1        | 1          | 800   | 40                           | 45.4                             | -5.4                    |
| 2        | 1          | 800   | 40                           | 54.0                             | -14                     |
| 3        | 1          | 800   | 40                           | 57.6                             | -17.6                   |
| 4        | 1          | 800   | 40                           | 55.8                             | -15.8                   |
| 5        | 1          | 800   | 40                           | 53.1                             | -13.1                   |
| 6        | 1          | 800   | 40                           | 50.4                             | -10.4                   |
| 7        | 1          | 800   | 40                           | 47.3                             | -7.3                    |
| 8        | 1          | 800   | 40                           | 45.1                             | -5.1                    |
| 9        | 1          | 800   | 40                           | 42.7                             | -2.7                    |
| 10       | 1          | 800   | 40                           | 40.3                             | -0.3                    |
| 11       | 1          | 800   | 40                           | 37.3                             | 2.7                     |
| 12       | 1          | 800   | 40                           | 38.1                             | 1.9                     |
| 13       | 1          | 800   | 40                           | 45.2                             | -5.2                    |
| 14       | 1          | 800   | 40                           | 44.8                             | -4.8                    |

### Reading from observation table:

For speed = 800 rpm

Pressure at point 1 = 40 cm of oil

Sommerfeld equation is given by

$$S_o = \left( \frac{r}{c} \right)^2 \left( \frac{\mu N}{P} \right) K_w \times 10^{-6}$$

Where,

$c$  = radial clearance = 3 mm = 0.0025 m

$r$  = radius of journal = 27.5 mm = 0.02625 m

$\mu$  = viscosity of oil =  $400 \times 10^{-3}$  NS/m<sup>2</sup>

$N = \text{Speed of the journal} = 800 \text{ rpm}$

$p = \text{bearing pressure in kg/mm}^2 \text{ (MN/m}^2\text{)}$

$K_w = \text{correction factor for side leakage}$

Calculation for p:

From manometer, Pressure = 40 cm of oil

Conversion into m of water = 400 x Specific gravity of oil

2.400 x 0.93 (from standard chart)

3.372 m of water

Conversion into  $\text{Kg/cm}^2 = 372 / 10 = 37.2 \text{ Kg/cm}^2$

{Where  $1 \text{ kg/cm}^2 = 10 \text{ m of water}$ }

Conversion into  $\text{Kg/mm}^2 = 372 / 100 = 3.72 \text{ Kg/mm}^2$

{Where  $1 \text{ Kg/mm}^2 = 100 \text{ Kg/cm}^2$ }

To obtain  $K_w$  from graph,

Refer graph given (fig. 1)

Calculation for B/L:

From table  $B = 2 \times \pi \times r \times (\beta/360)$

(Where  $\beta = \text{angle of radial point} = 30$ )

$= 2 \times \pi \times 0.02625 \times (30/360)$

$= 0.0137 \text{ m}$

$L = 0.090 \text{ m}$

Therefore  $B/L = 0.0137/0.09 = 0.152$

From graph for  $B/L = 0.152$  and  $h_o/c = 0.6$

Therefore substituting above in Sommerfield equation

$$S_o = \left( \frac{r}{c} \right)^2 \left( \frac{\mu N}{P} \right) K_w \times 10^{-6}$$

$= (0.02625/0.0025)^2 \times \{(400 \times 10^{-3} \times 800)/0.372\} \times 0.85 \times 10^{-6}$

$= 80,430 \times 10^{-6} \text{ in s/min}$

Note: Similarly calculate for all the pressure points to get different Sommerfield number.

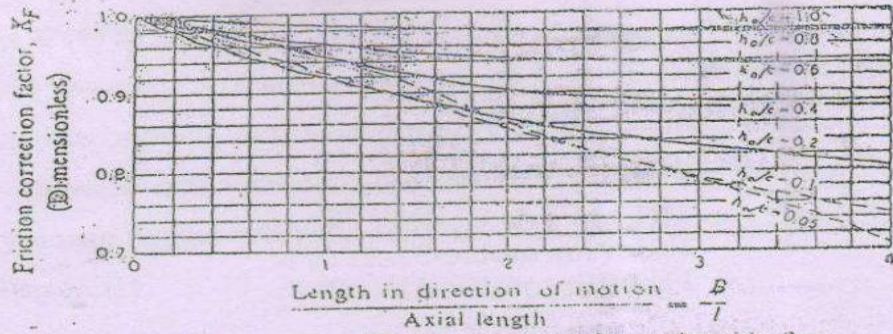

Fig. Friction correction factor for side flow

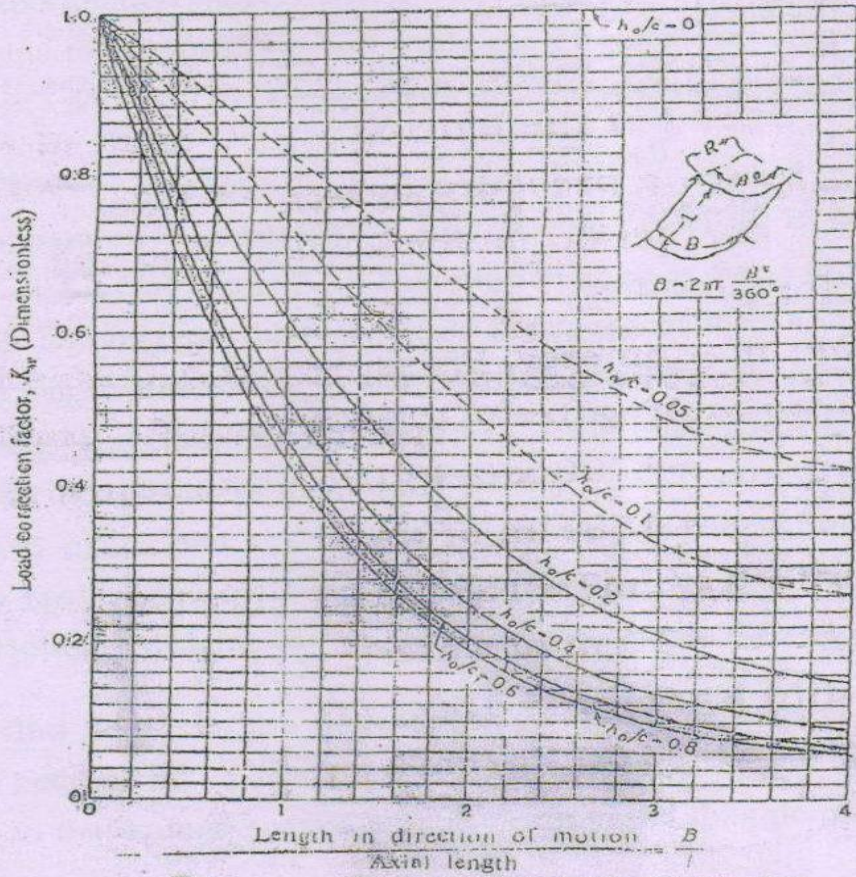
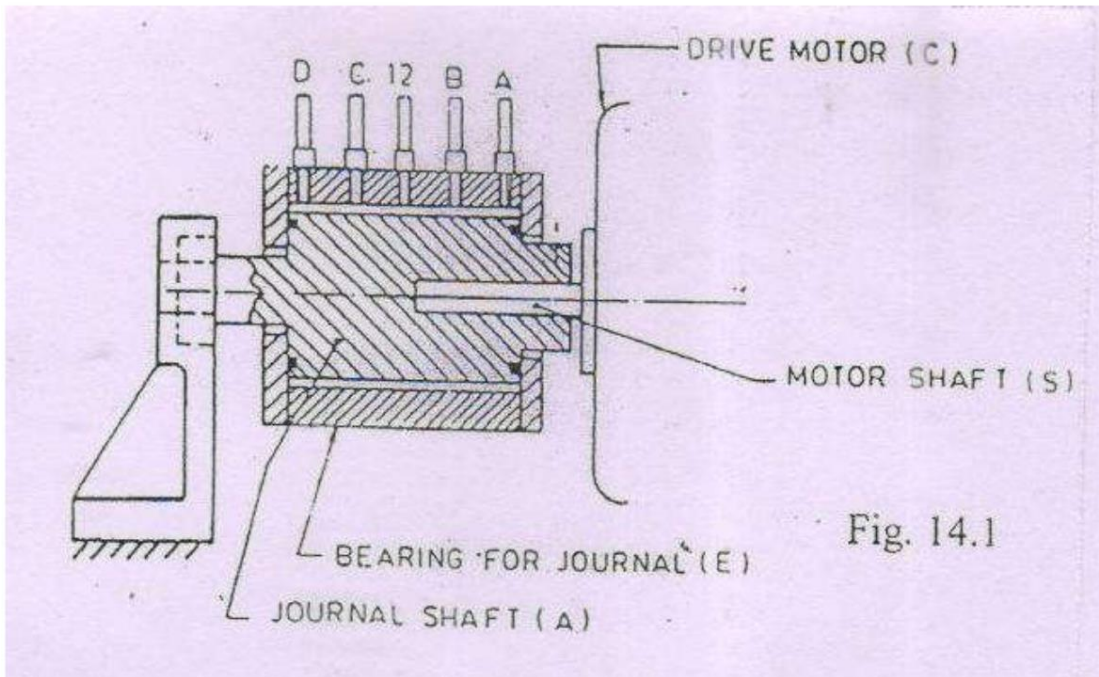
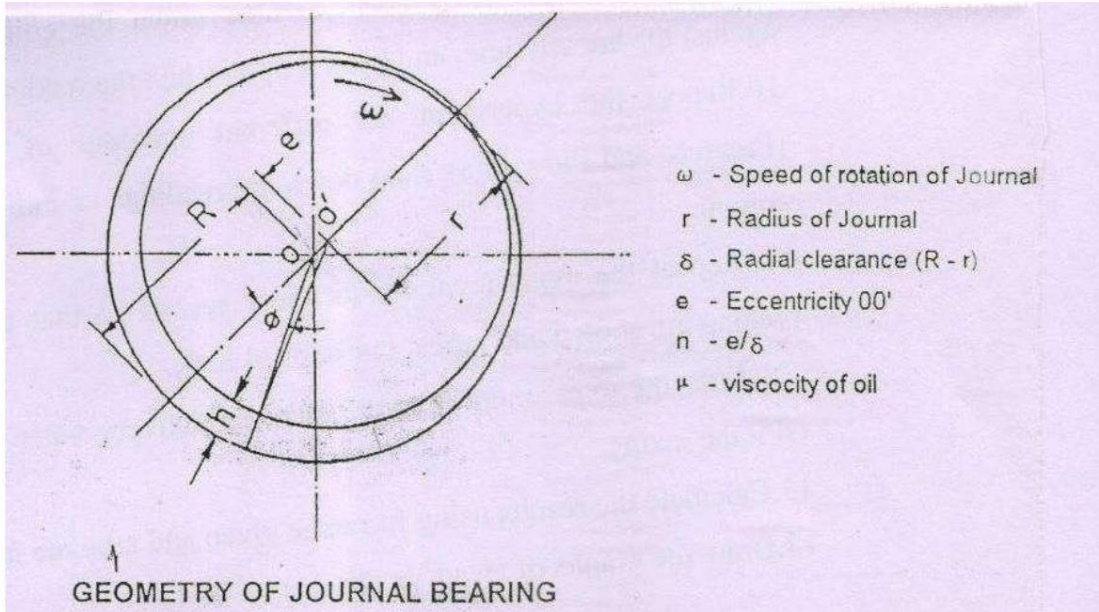

Fig. Load correction factor for side flow





## EXPERIMENT NO 04

### CAM AND FOLLOWER

#### AIM

Study of different types of Cam and followers

#### INTRODUCTION

Cam - A mechanical device used to transmit motion to a follower by direct contact. Where Cam – driver member, Follower - driven member.

cam is a rotating machine element which gives reciprocating or oscillating motion to another element known as follower. The cam and the follower have a line contact and constitute a higher pair.

The cams are usually rotated at uniform speed by a shaft, but the follower motion is predetermined and will be according to the shape of the cam. The cam and follower is one of the simplest as well as one of the most important mechanisms found in modern machinery today.

#### APPLICATIONS:

The cams are widely used for operating the inlet and exhaust valves of Internal combustion engines, automatic attachment of machineries, paper cutting machines, spinning and weaving textile machineries, feed mechanism of automatic lathes.

#### Example of cam action

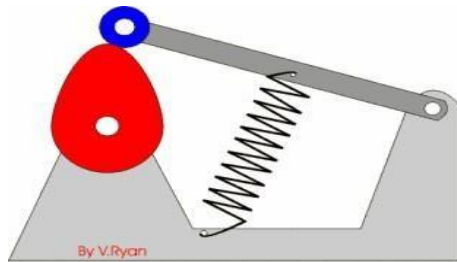

#### CLASSIFICATION OF FOLLOWERS

##### 1. Based on surface in contact. (Fig.1)

(a) **Knife edge follower.** When the contacting end of the follower has a sharp knife edge, it is called a knife edge follower, as shown in Fig. 1 (a). The sliding motion takes place between the contacting surfaces (i.e. the knife edge and the cam surface). It is seldom used in practice because the small area of contacting surface results in excessive wear. In knife edge followers, a considerable side thrust exists between the follower and the guide.

(b) **Roller follower.** When the contacting end of the follower is a roller, it is called a roller follower, as shown in Fig. 1 (b). Since the rolling motion takes place between the contacting surfaces (i.e. the roller and the cam), therefore the rate of wear is greatly reduced. In roller followers also the side thrust exists between the follower and the guide. The roller followers are extensively used where more space is available such as in stationary gas and oil engines and aircraft engines

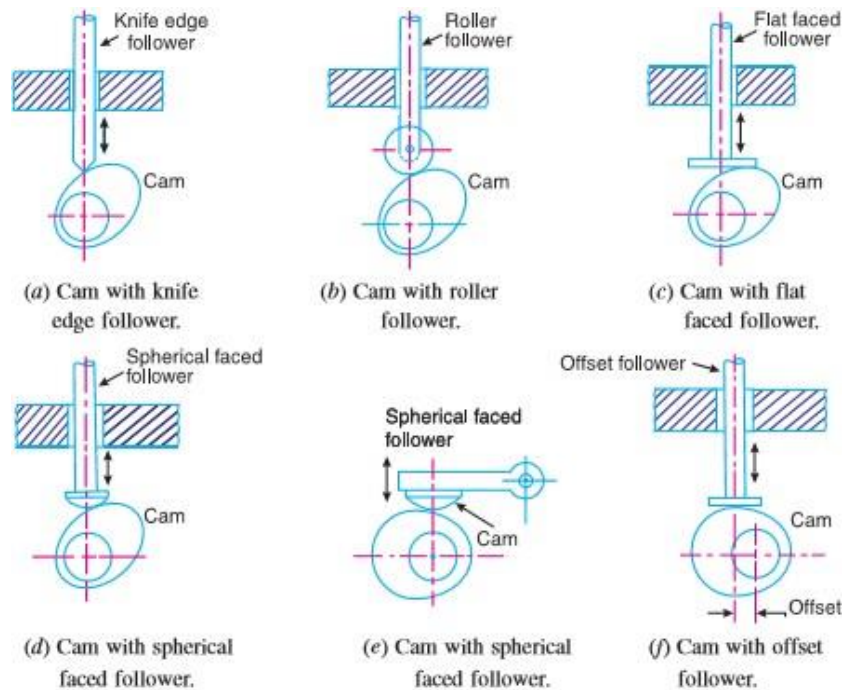

Fig. 1.Types of followers

(c) **Flat faced or mushroom follower.** When the contacting end of the follower is a perfectly flat face, it is called a flat-faced follower, as shown in Fig. 1 (c). It may be noted that the side thrust between the follower and the guide is much reduced in case of flat faced followers. The only side thrust is due to friction between the contact surfaces of the follower and the cam. The relative motion between these surfaces is largely of sliding nature but wear may be reduced by off-setting the axis of the follower, as shown in Fig. 1 (f) so that when the cam rotates, the follower also rotates about its own axis. The flat faced followers are generally used where space is limited such as in cams which operate the valves of automobile engines.

(d) **Spherical faced follower.** When the contacting end of the follower is of spherical shape, it is called a spherical faced follower, as shown in Fig. 1 (d). It may be noted that when a flat-faced follower is used in automobile engines, high surface stresses are produced. In order to minimize these stresses, the flat end of the follower is machined to a spherical shape

## 2. According to the motion of the follower

(a) **Reciprocating or translating follower.** When the follower reciprocates in guides as the cam rotates uniformly, it is known as reciprocating or translating follower. The followers as shown in Fig. 1 (a) to (d) are all reciprocating or translating followers

(b) **Oscillating or rotating follower.** When the uniform rotary motion of the cam is converted into predetermined oscillatory motion of the follower, it is called oscillating or rotating follower. The follower, as shown in Fig 1 (e), is an oscillating or rotating follower.

## 3. According to the path of motion of the follower

(a) **Radial follower.** When the motion of the follower is along an axis passing through the centre of the cam, it is known as radial follower. The followers, as shown in Fig. 1 (a) to (e), are all radial followers.

(b) **Off-set follower.** When the motion of the follower is along an axis away from the axis of the cam centre, it is called off-set follower. The follower, as shown in Fig. 1 (f), is an off-set follower.

## CLASSIFICATION OF CAMS

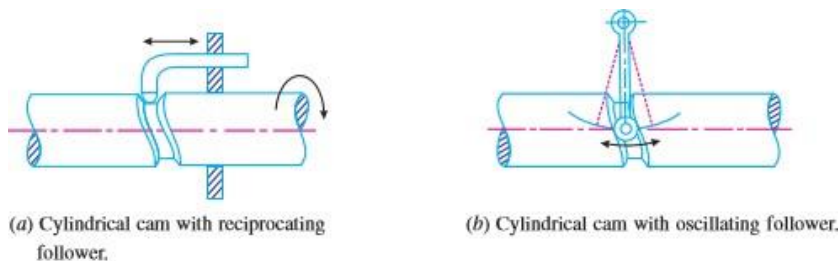

Fig 2 cams

(a) **Radial or disc cam.** In radial cams, the follower reciprocates or oscillates in a direction perpendicular to the cam axis. The cams as shown in Fig. 1 are all radial cams.

(b) **Cylindrical cam.** In cylindrical cams, the follower reciprocates or oscillates in a direction parallel to the cam axis. The follower rides in a groove at its cylindrical surface. A cylindrical grooved cam with a reciprocating and an oscillating follower is shown in Fig. 2 (a) and (b) respectively



# EXPERIMENT NO 05

## EPICYCLIC GEAR TRAIN

### AIM

Study & demonstration of epicyclic gear train

### THEORY

In an epicyclic gear train, the axes of the shafts, over which the gears are mounted, may move relative to a fixed axis. A simple epicyclic gear train is shown in Fig. where a gear A and the arm C have a common axis at  $O_1$  about which they can rotate. The gear B meshes with gear A and has its axis on the arm at  $O_2$ , about which the gear B can rotate. If the arm is fixed, the gear train is simple and gear A can drive gear B or vice versa, but if gear A is fixed and the arm is rotated about the axis of gear A (i.e.  $O_1$ ), then the gear B is forced to rotate *upon* and *around* gear A. Such a motion is called epicyclic and the gear trains arranged in such a manner that one or more of their member's moves upon and around another member are known as *epicyclic gear trains* (*epi* - means upon and *cyclic* means around). The epicyclic gear trains may be *simple or compound*.

**Epicyclic gear train.**

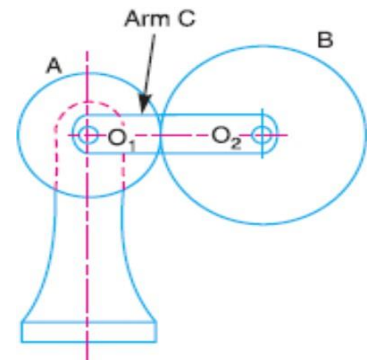

### Application

The epicyclic gear trains are useful for transmitting high velocity ratios with gears of moderate size in a comparatively lesser space. The epicyclic gear trains are used in the back gear of lathe, differential gears of the automobiles, hoists, pulley blocks, wrist watches etc.

### PROCEDURE

For finding out the Velocity Ratios of Epicyclic Gear Train

Let

$T_A$  = Number of teeth on gear A,

$T_B$  = Number of teeth on gear B,

1. Calculate number teeth of Gear A and Gear B.
2. Let us suppose that the arm is fixed. Therefore the axes of both the gears are also fixed relative to each other. When the gear A makes one revolution anticlockwise, the gear B will make  $T_A / T_B$  revolutions, clockwise. Assuming the anticlockwise rotation as positive and clockwise as negative, Then when gear A makes + 1 revolution, then the gear B will make  $- T_A / T_B$  revolutions. This statement of relative motion is entered in the first row of the table.
3. If the gear A makes +  $x$  revolutions, then the gear B will make  $- x \times T_A / T_B$  revolutions. This statement is entered in the second row of the table.
4. Each element of an epicyclic train is given +  $y$  revolutions and entered in the third row.
5. Finally, the motion of each element of the gear train is added up and entered in the fourth row
6. When two conditions about the motion of rotation of any two elements are known, then the unknown speed of the third element may be calculated by substituting the given data in the third column of the fourth row.
7. After finding out the speed of Gear A and B the velocity ration can be obtained.

### TABULATION

| Step No. | Conditions of motion   | Revolutions of elements |           |                                |
|----------|--|-------------------------|-----------|--------------------------------|
|          |  | Arm C                   | Gear A    | Gear B                         |
| 1.       | Arm fixed-gear A rotates through + 1 revolution <i>i.e.</i> 1 rev. anticlockwise | 0                       | + 1       | $-\frac{T_A}{T_B}$             |
| 2.       | Arm fixed-gear A rotates through + $x$ revolutions                               | 0                       | + $x$     | $-x \times \frac{T_A}{T_B}$    |
| 3.       | Add + $y$ revolutions to all elements  | + $y$                   | + $y$     | + $y$                          |
| 4.       | Total motion   | + $y$                   | + $x + y$ | $y - x \times \frac{T_A}{T_B}$ |

### CALCULATION

### RESULT

## EXPERIMENT NO 06

### VERNIER CALIPER

#### AIM

Determination of the thickness of ground M.S flat to an accuracy of 0.02mm using Vernier Caliper

#### APPARATUS REQUIRED

| SL.NO | Name of the Items | Specification                | Quantity |
|-------|-------------------|------------------------------|----------|
| 01.   | Vernier caliper   | 150mm.                       | 01       |
| 02.   | M.S Flat          | (150x50x6)mm<br>(100x50x6)mm | 02.      |

#### THEORY

##### Vernier Caliper

The Vernier caliper has one 'L' shaped frame with a fixed jaw on which Vernier scale is attached.

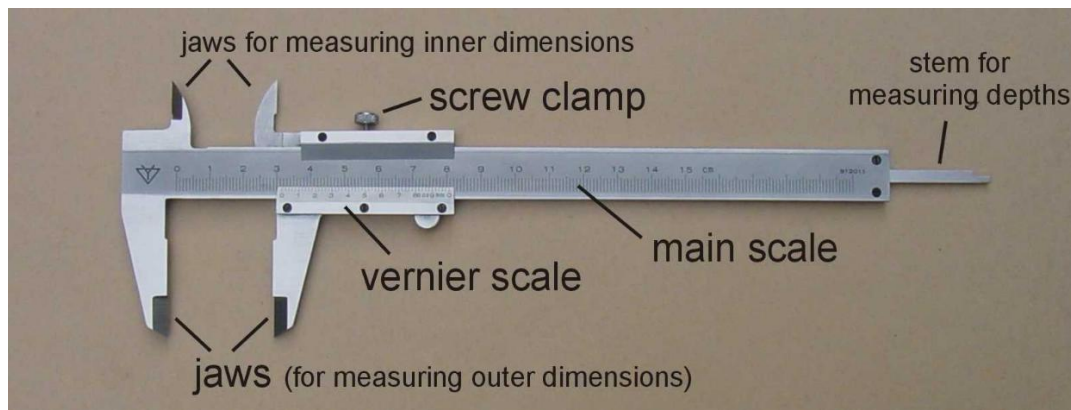

Figure 1 Vernier Instruments

The principle of vernier is that when two scales or divisions slightly different in size are used, the difference between them can be utilized to enhance the accuracy of measurement. The vernier calliper essentially consists of two steel rules and these can slide along each other. One of the scales, i.e., main scale is engraved on a solid L-shaped frame. One end of the frame contains a fixed jaw which is shaped into a contact tip at its extremity.

The three elements of vernier caliper, viz, beam, fixed jaw, and sliding jaw permit substantial improvements in the commonly used measuring techniques over direct measurement with line graduated rules. The alignment of the distance boundaries with the corresponding graduations of the rule is ensured by means of the positive contact members (the jaws of the caliper

gauges). The datum of the measurement can be made to coincide precisely with one of the

boundaries of the distance to be measured. The movable jaw achieves positive contact with the object boundary at the opposite end of the distance to be measured. The closely observable correspondence of the reference marks on the slide with a particular scale value significantly reduces the extent of read-out alignment errors.

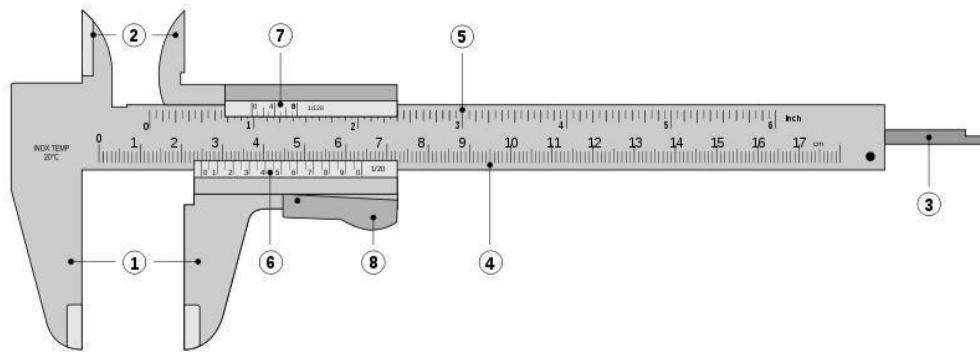

Figure 2 Vernier Instruments

A sliding jaw which moves along the guiding surface provided by the main scale is coupled to a vernier scale. The sliding jaw at its left extremity contains another measuring tip. When two measuring tip surfaces are in contact with each other, scale shows zero reading. The finer adjustment of the movable jaw can be done by the adjusting screw. First the whole movable jaw assembly is adjusted so that the two measuring tips just touch the part to be measured. Then lock nut is tightened. Final adjustment depending upon the sense of correct feel is made by the adjusting screw. The movement of adjusting screw makes the part containing locking nut and sliding jaw to move, as the adjusting screw rotates on a screw which is in a way fixed to the movable jaw. After final adjustment has been made, the locking nut A is also tightened and the reading is noted down. The measuring tips are so designed as to measure inside as well as outside dimensions.

1. Outside jaws: used to measure external diameter or width of an object
2. Inside jaws: used to measure internal diameter of an object
3. Depth probe: used to measure depths of an object or a hole
4. Main scale: gives measurements of up to one decimal place (in cm).
5. Main scale: gives measurements in fraction (in inch)
6. Vernier gives measurements up to two decimal places (in cm)
7. Vernier gives measurements in fraction (in inch)
8. Retainer: used to block movable part to allow the easy transferring a measurement

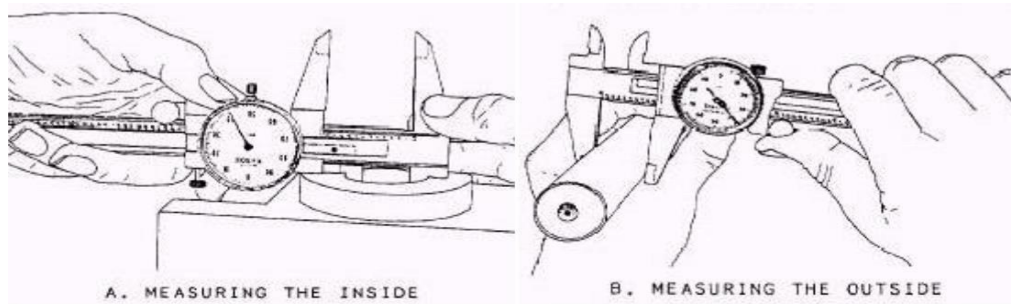

Figure 3 Practical Applications of Vernier Calipers

### PROCEDURE

1. The least count is to be determined
2.  $L.C = 1 \text{ main scale division} - 1 \text{ vernier scale division}$
3. The work piece is placed between the jaws of vernier calliper.
4. The reading on the main scale which is just behind the first vernier scale division is noted as main scale reading (MSR)
5. The division on the vernier scale which coincides with the line on main scale is noted down as vernier coincidence (VSD)
6. The thickness (MD) can be calculated using the given formula

**Least Count** is the smallest length that can be measured accurately and is equal to the difference between a main scale division and a Vernier scale division.

$$\text{LEAST COUNT} = 1 \text{ Main scale division} - 1 \text{ Vernier scale division}$$

### OBSERVATION:-

$$50 \text{ V.S.D} = 49 \text{ M.S.D}$$

$$1 \text{ V.S.D} = 49/50 \text{ M.S.D}$$

$$1 \text{ M.S.D} = 1 \text{ mm.}$$

$$\begin{aligned} \text{Least count} &= 1 \text{ M.S.D} - 1 \text{ V.S.D} \\ &= 1 \text{ mm} - 49/50 \\ &= 0.02 \text{ mm.} \end{aligned}$$

$$\text{MD} = [\text{MSR} + (\text{VSD} \times \text{LC})]$$

- MD-Measured Dimension
- MSR-Main Scale Reading
- VSD-Vernier Scale Division
- LC-Least Count

## TABULATION

| Least Count of vernier = 0.02mm<br>Vernier Calliper Reading 'mm' |     |     |            |             | Remark |
|--|-----|-----|------------|-------------|--------|
| Sl no  | MSR | VSD | VSR=VSDXLC | MD=MSR +VSR |        |
| 1  |     |     |            |             |        |
| 2  |     |     |            |             |        |
| 3  |     |     |            |             |        |
| 4  |     |     |            |             |        |
| 5  |     |     |            |             |        |

## RESULT:

## CONCLUSION:

The precision measuring instrument vernier calliper is studied and thickness of ground M.S flat is measured to an accuracy of 0.02mm using Vernier Caliper.

# EXPERIMENT NO 07

## MICROMETER

### AIM

Determination of diameter of a cylindrical component to an accuracy of 0.01mm using micrometer

### APPARATUS REQUIRED

| SL.NO | Name of the Items     | Specification | Quantity |
|-------|-----------------------|---------------|----------|
| 01    | Outside Micrometer    | (0.25mm)      | 01       |
| 02    | Digital Micrometer    | (0.25mm)      | 01       |
| 03    | Cylindrical component | 20x50mm       | 02       |

### THEORY

#### Micrometer

The micrometer screw gauge essentially consists of an accurate screw having about 10 or 20 threads per cm and revolves in a fixed nut. The end of the screw forms one measuring tip and the other measuring tip is constituted by a stationary anvil in the base of the frame. The screw is threaded for certain length and is plain afterwards. The plain portion is called sleeve and its end is the measuring surface. The spindle is advanced or retracted by turning a thimble connected to the spindle. The spindle is a slide fit over the barrel and barrel is the fixed part attached with the frame.. A lock nut is provided for locking a dimension by preventing motion of the spindle.

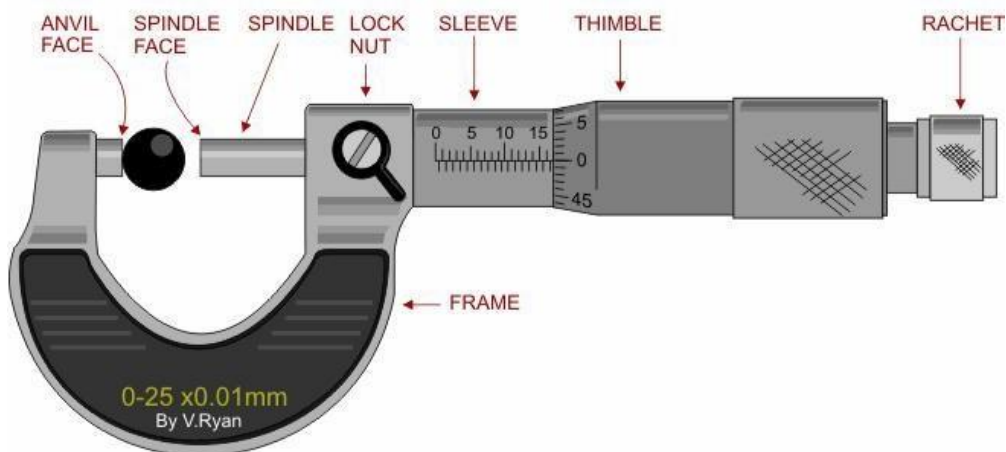

Ratchet stop is provided at the end of the thimble cap to maintain sufficient and uniform measuring pressure so that standard conditions of measurement are attained. Ratchet stop consists of an overriding clutch held by a weak spring. When the spindle is brought into contact with the work at the correct measuring pressure, the clutch starts slipping and no further movement of the spindle takes place by the rotation of ratchet. In the backward movement it is positive due to shape of ratchet.



LEAST COUNT = Pitch scale division / Number of threads

Pitch scale division = Distance moved / number of rotation

**USES:-**

1. Outside micrometer is used to measure the diameter of solid cylinder.
2. Inside micrometer is used to measure the internal diameters of hollow cylinders and spheres.

**PROCEDURE:-**

1. The micrometer is checked for Zero error
2. The given component is held between the face of the unvil and the spindle
3. The spindle is moved by rotating the thimble until the anvil and spindle touches the cylindrical surface of the component
4. Final adjustment is made by ratchet. The main scale reading and thimble scale reading is noted
5. Two more reading are taken at different place of the component
6. The readings are tabulated and calculated.

**OBSERVATION:-**

Least count:-

The distance moved by the spindle during one rotation of thimble is 0.5mm.

Movement of one division of the Thimble =  $0.5 \times 1/50 = 0.01\text{mm}$ .

**TABULATION:-**

| Least Count of micrometer= 0.01mm |                   |                  |             |                                 |      |         |                            |       |
|-----------------------------------|-------------------|------------------|-------------|---------------------------------|------|---------|----------------------------|-------|
| Micrometer Reading 'mm'           |                   |                  |             |                                 |      |         |                            |       |
| SL.NO                             | Barrel Reading(x) | Thimble Division | Least Count | Thimble(y) Reading<br>L.C x T.D | X +Y | Reading | Digital micrometer Reading | Error |
| 01                                |                   |                  |             |                                 |      |         |                            |       |
| 02                                |                   |                  |             |                                 |      |         |                            |       |
| 03                                |                   |                  |             |                                 |      |         |                            |       |
| 04                                |                   |                  |             |                                 |      |         |                            |       |
| 05                                |                   |                  |             |                                 |      |         |                            |       |

**RESULT:**

**CONCLUSION:**

The precision measuring instrument micrometer is studied and diameter of a cylindrical component is measured using an accuracy of 0.01mm using micrometer.

## EXPERIMENT NO 08

### VERNIER HEIGHT GAUGE

#### AIM

Determine the heights of gauge blocks or parallel bars to accuracy of 0.02mm using Vernier height gauge.

#### APPARATUS REQUIRED

| SL.NO | Name of the Items    | Specification    | Quantity |
|-------|----------------------|------------------|----------|
| 01    | Vernier height gauge | 300mm            | 01       |
| 03    | Parallel bars        | 100 x50 x 6mm    | 02`      |
| 04    | Gauge blocks         | 1 boxes(81 pc s) | 1 box    |

#### THEORY

##### Vernier height gauge

Vernier height gauge is similar to vernier calliper but in this instrument the graduated bar is held in a vertical position and it is used in conjunction with a surface plate.

##### Construction:

A vernier height gauge consists of

1. A vernier height gauge consists of A finely ground and lapped base. The base is massive and robust in construction to ensure rigidity and stability.
2. A vertical graduated beam or column supported on a massive base.
3. Attached to the beam is a sliding vernier head carrying the vernier scale and a clamping screw.
4. An auxiliary head which is also attached to the beam above the sliding vernier head. It has fine adjusting and clamping screw.
5. A measuring jaw or a scriber attached to the front of the sliding vernier

##### Use.

The vernier height gauge is designed for accurate measurements and marking of vertical heights above a surface plate datum. It can also be used to measure differences in heights by taking the vernier scale readings at each height and determining the difference by subtraction. It can be used for a number of applications in the tool room and inspection department. The important features of vernier height gauge are:

All the parts are made of good quality steel or stainless steel.

- The beam should be sufficiently rigid square with the base.
- The measuring jaw should have a clear projection from the edge of the beam at least equal to the projection of the base' from the beam.

- The upper and lower gauging surfaces of the measuring jaw shall be flat and parallel to the base.
- The scriber should also be of the same nominal depth as the measuring jaw so that it may be reversed.
- The projection of the jaw should be at least 25 mm

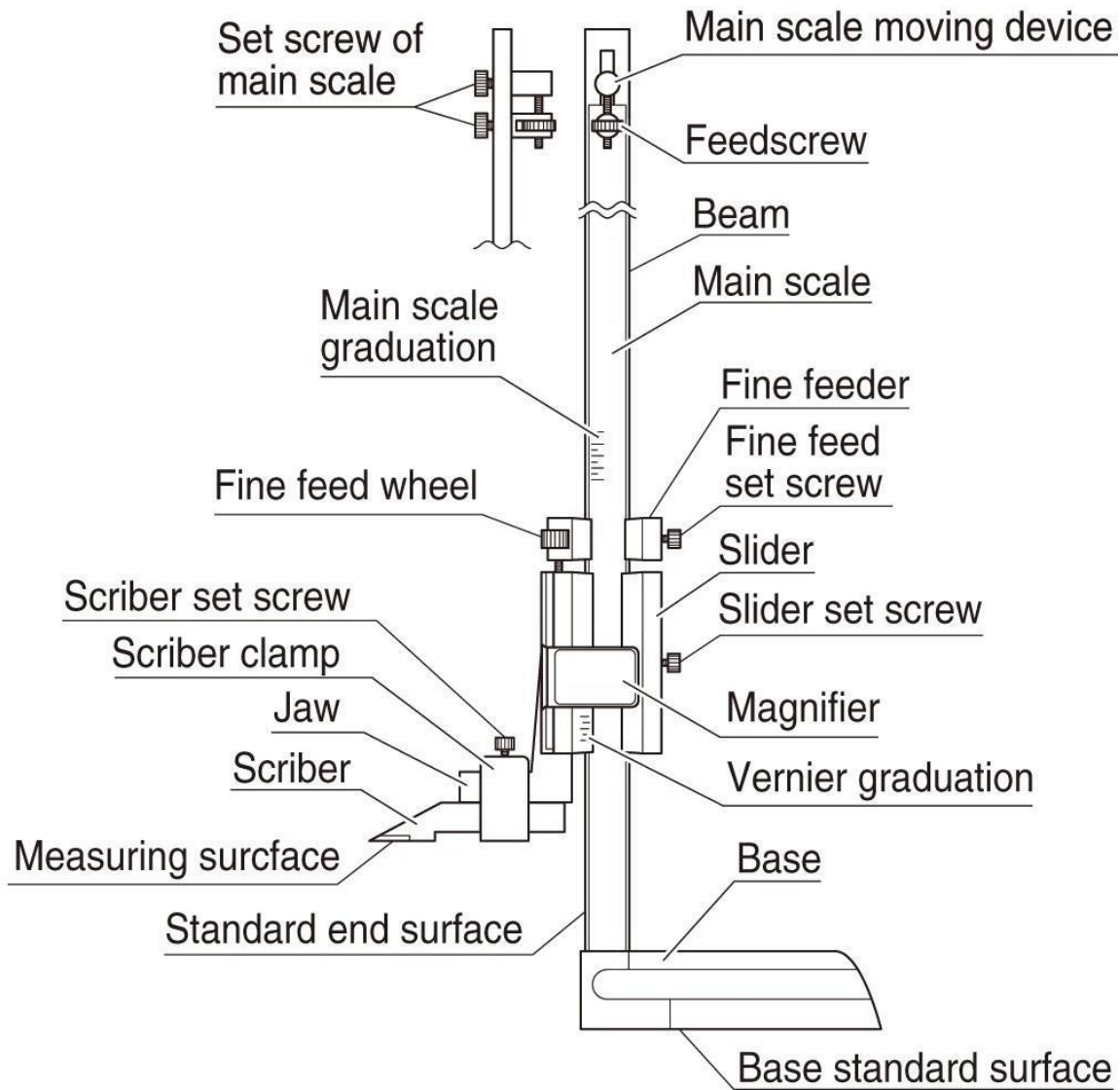

## PROCEDURE

1. Clean the main scale, Vernier scale and measuring jaws of the Vernier Height gauge
2. The vernier height gauge is checked for zero error
3. Place the job in Surface plate.
4. Place the measuring jaw such that it touches the surface to be measured from the Smooth surface
5. Measure the main scale reading and Vernier scale coincidence of the Vernier Height gauge

**OBSERVATION:-**

$$50 \text{ V.S.D} = 49 \text{ M.S.D}$$

$$1 \text{ V.S.D} = 49/50 \text{ M.S.D}$$

$$1 \text{ M.S.D} = 1\text{mm.}$$

$$\begin{aligned} \text{Least count} &= 1 \text{ M.S.D} - 1 \text{ V.S.D} \\ &= 1\text{mm} - 49/50 \\ &= 0.02\text{mm} \end{aligned}$$

**FORMULA**

$$\text{MD} = [\text{MSR} + (\text{VSC} \times \text{LC})]$$

- MD-Measured Dimension
- MSR-Main Scale Reading
- VSC-Vernier Scale Coincide
- LC-Least Count

**TABULATION:**

| Least Count of vernier = 0.02mm<br>Vernier height gauge Reading 'mm' |     |     |            |             |
|--|-----|-----|------------|-------------|
| Sl no  | MSR | VSC | VSR=VSCXLC | MD=MSR +VSR |
| 1  |     |     |            |             |
| 2  |     |     |            |             |
| 3  |     |     |            |             |
| 4  |     |     |            |             |
| 5  |     |     |            |             |

**RESULT:****CONCLUSION:**

The precision measuring instrument vernier height gauge is studied and thickness of mild steel flat specimen is measured.

## EXPERIMENT NO-09

### SLIP GAUGES

#### AIM

Determination the thickness of M.S. Plates using slip gauges.

#### APPARATUS REQUIRED:-

| SL.NO | Name of the Items    | Specification           | Quantity |
|-------|----------------------|-------------------------|----------|
| 01    | M.S Plates           | (100 x 50 x 06)mm       | 02       |
| 02    | Slip gauge           | (0-83), 30mm x 9mm size | 1 box    |
| 03    | Surface Plate        | 300 x 300               | 01       |
| 04    | Vernier height gauge | 300mm                   | 01       |

#### THEORY:-

Slip gauges or gauge blocks are universally accepted end standard of length in industry. These were introduced by Johnson, a Swedish engineer, and are also called as johanson gauges

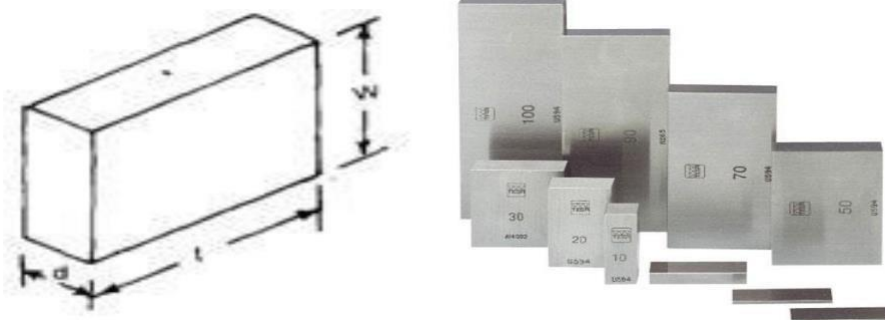

*Figure Dimensions of a Slip Gauge*

Slip gauges are rectangular blocks of high grade steel with exceptionally close tolerances. These blocks are suitably hardened through out to ensure maximum resistance to wear. They are then stabilized by heating and cooling successively in stages so that hardening stresses are removed, After being hardened they are carefully finished by high grade lapping to a high degree of finish, flatness and accuracy. For successful use of slip gauges their working faces are made truly flat and parallel. A slip gauge is shown in fig. Slip gauges are also made from tungsten carbide which is extremely hard and wear resistance.

The cross-sections of these gauges are 9 mm x 30 mm for sizes up to 10 mm and 9 mm x 35 mm for larger sizes. Any two slips when perfectly clean may be wrung together. The dimensions are permanently marked on one of the measuring faces of gauge blocks Gauges blocks are used for:

1. Direct precise measurement, where the accuracy of the work piece demands it.
2. For checking accuracy of vernier callipers, micrometers, and such other measuring instruments.

3. Setting up a comparator to a specific dimension.
4. For measuring angle of work piece and also for angular setting in conjunction with a sine bar.
5. The distances of plugs, spigots, etc. on fixture are often best measured with the slip gauges or end bars for large dimensions.
6. To check gap between parallel locations such as in gap gauges or between two mating parts.

**PROCEDURE:-**

1. At first we cleaned the surface of slip gauge.
2. Then we inserted the slip gauge for measuring the thickness by taking attention such that minimum number of slip gauges is used.
3. Than we removed the gauge from jobs.
4. We calculated the thickness by adding individual slip gauge reading which is mentioned on the surface of slip gauge.
5. In this way by repeating above procedure we took 5 reading.

For measuring the thickness of M.S plate by using set of 112 pieces.

| Range in mm    | Steps | No of pieces |
|----------------|-------|--------------|
| 1.005          |       | 01           |
| 1.001 to 1.009 | 0.001 | 09           |
| 1.01 to 1.49   | 0.01  | 49           |
| 05 to 24.5     | 0.05  | 49           |
| 25 to 100      | 25.00 | 04           |

**TABULATION:-**

| SL .NO | Select the slip gauges | Select the slip | Select 2 <sup>nd</sup> | Select 3 <sup>rd</sup> | Select 4 <sup>th</sup> | Total reading | Average reading |
|--------|------------------------|-----------------|------------------------|------------------------|------------------------|---------------|-----------------|
| 01     | 1.005                  | 1.002           | 1.37                   | 1.5                    | 0                      | 4.8725        | 4.1515          |
| 02     | 1.0005                 | 1.003           | 1.25                   | 2                      | 0                      | 5.2535        |                 |
| 03     | 1.0005                 | 1.001           | 1.15                   | 1.2                    | 0                      | 4.1515        |                 |
| 04     | 1.0005                 | 0.008           | 1.13                   | 0.5                    | 0                      | 3.6385        |                 |
| 05     | 1.0005                 | 1.008           | 1.45                   | 2.5                    | 0                      | 5.9585        |                 |

**CONCLUSION:-**

From the above experiment we find the thickness of M.S plate by using the range of slip gauges.

## **EXPERIMENT NO 10**

### **ANGULAR MEASUREMENT USING SINE BAR**

#### **AIM**

Determination of angle of Machined surfaces of components using sin bar with slip gauge

#### **APPARATUS REQUIRED:**

| SL.NO | Name of the Items                 | Specification | Quantity |
|-------|-----------------------------------|---------------|----------|
| 01    | One machined surface in any angle |               | 01       |
| 02    | Sine bar                          | 200mm         | 01       |
| 03    | Slip gauge box                    | (0-83) pcs    | 01 set   |

#### **Sine Principle and Sine Bars**

The sine principle uses the ratio of the length of two sides of a right triangle in deriving a given angle. It may be noted that devices operating on sine principle are capable of “self generation.” The measurement is usually limited to  $45^{\circ}$  from loss of accuracy point of view. The accuracy with which the sine principle can be put to use is dependent in practice, on some form of linear measurement. The sine bar in itself is not a complete measuring instrument. Another datum such as a surface plate is needed, as well as other auxiliary equipment, notably slip gauges, and indicating device to make measurements. Sine bars used in conjunction with slip gauges constitute a very good device for the precise measurement of angles. Sine bars are used either to measure angles very accurately or for locating any work to a given angle within very close limits. Sine bars are made from high carbon, high chromium, corrosion resistant steel, hardened, ground and stabilized.

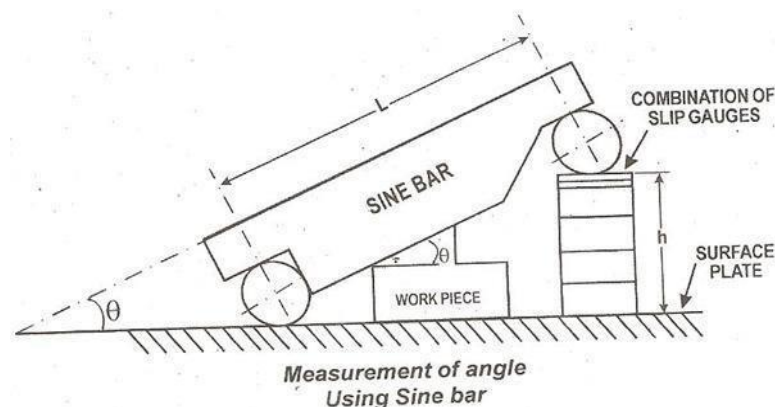

#### **PROCEDURE**

1. The given component is placed on the surface plate.
2. One roller of sine bar is placed on surface plate and bottom surface of sine bar is seated

on the taper surface of the component.

3. The combination of slip gauges is inserted between the second roller of sine bar and the surface plate.
4. The angle of the component is then calculated by the formula given below

**FORMULA:**

$$\sin \theta = H/L$$

Where,

H = (h<sub>1</sub>-h<sub>2</sub>) =Height of the slip gauge

L - Distance between the centres

**TABULATION**

| SL.NO | h1 in mm. | h2 in mm. | h1-h2 in mm. | L in mm | Sin θ=h1-h2/L<br>in(0) | θ=sin <sup>-1</sup> (h1-h2)/L<br>in radian |
|-------|-----------|-----------|--------------|---------|------------------------|--|
| 1     | 3.25      | 1.5       | 1.75         | 200     | 1.75/200               | 5 radian=28.72                             |
|       |           |           |              |         |                        |  |
|       |           |           |              |         |                        |  |
|       |           |           |              |         |                        |  |
|       |           |           |              |         |                        |  |
|       |           |           |              |         |                        |  |

**RESULT**

Thus the angle in the work pieces were Determined using Sine bar

Angle measured in work piece ,1 =-----‘degree’

Angle measured in work piece ,2 =-----‘degree’