



Email ID: [gpbmsmechanicalengg@gmail.com](mailto:gpbmsmechanicalengg@gmail.com)

**DEPARTMENT OF MECHANICAL ENGINEERING**  
**GOVT. POLYTECHNIC, BALASORE**

---

**LAB MANUAL**  
**MECHANICAL ENGINEERING -II (Pr.2)**  
**4<sup>TH</sup> SEMESTER**



**GOVT. POLYTECHNIC, BALASORE**

## GENERAL LABORATORY INSTRUCTIONS

- You should be punctual for your laboratory session and should not leave the lab without the permission of the teacher.
- Each student is expected to have his/her own lab book where they will take notes on the experiments as they are completed.
- The lab books will be checked at the end of each lab session. Lab notes are a primary source from which you will write your lab reports.
- You and your batch mates will work closely on the experiments together. One partner doing all the work will not be tolerated. All the Batch mates should be able to explain the purpose of the experiment and the underlying concepts.
- Please report immediately to the member of staff or lab assistant present in the laboratory; if any equipment is faulty.

## **ORGANIZATION OF THE LABORATORY**

- It is important that the experiments are done according to the timetable and completed within the scheduled time.
- You should complete the pre lab work in advance and utilize the Laboratory time for verification only.
- The aim of these exercises is to develop your ability to understand, analyze and test them in the laboratory.
- A member of staff and a Lab assistant will be available during Scheduled laboratory sessions to provide assistance.
- Always attempt experiments; first without seeking help.
- When you get into difficulty; ask for assistance.

## **ASSESSMENT**

- The laboratory work of a student will be evaluated continuously during the semester for 25 marks. Of the 25 marks, 15 marks will be awarded for day-to-day work.
- For each experiment marks are awarded under three heads:
  - Pre lab preparation - 5 marks
  - Practical work - 5marks, and
  - Record of the Experiment - 5marks
- Internal lab test(s) conducted during the semester carries 10 marks.
- End semester lab examination, conducted as per the JNTU regulations, carries 50 marks.
- At the end of each laboratory session you must obtain the signature of the teacher along with the marks for the session out of 10 on the lab notebook.

## **LAB REPORTS**

- Note that, although students are encouraged to collaborate during lab, each must individually prepare a report and submit.
- They must be organized, neat and legible.
- Your report should be complete, thorough, understandable and literate.
- You should include a well-drawn and schematic for each experiments Investigated.
- Your reports should follow the prescribed format, to give your report structure and to make sure that you address all of the important points.
- Graphics requiring- drawn straight lines should be done with a straight edge. Well drawn freehand sketches are permissible for schematics.
- Space must be provided in the flow of your discussion for any tables or figures. Do not collect figures and drawings in a single appendix at the end of the report.
- Reports should be submitted within one week after completing a scheduled lab session.

## **PRESENTATION**

- Experimental facts should always be given in the past tense.
- Discussions or remarks about the presentation of data should mainly be in the present tense.
- Discussion of results can be in both the present and past tenses, shifting back and forth from experimental facts to the presentation.
- Any specific conclusions or deductions should be expressed in the past tense.

## **REPORT FORMAT**

### **Lab write ups should consist of the following sections:**

- **Aim:** A concise statement describing the experiment and the results. This is usually not more than 3 sentences. Since the abstract is a summary of what you have done, it's a good idea to write this last.
- **Apparatus:** Describe what equipment and components you used to conduct the experiment.
- **Theory:** Several paragraphs that explain the motivation of the experiment. Usually in this statement you state what you intent to accomplish as well as the expected results of the experiment.
- **Procedure:** Describe how you conducted the experiment.
- **Results and Analysis:** This is the main body of the report. Graphs, tables, schematics, diagrams should all be included and explained. Results of any calculations should be explained and shown. State the results of the experiment. Include any problems encountered.
- **Conclusion:** Explain how the experiment went, and whether you were able to achieve the expected results stated in the introduction.

**General Rules:**

1. Lab Access: Only authorized personnel should have access to the lab.
2. Attire: Wear appropriate lab attire, including safety goggles, closed-toe shoes, and lab coats.
3. No Food or Drinks: Eating, drinking, and chewing gum should be prohibited inside the lab area.
4. Equipment Use: Use equipment only if you are trained and authorized to do so.
5. Follow Procedures: Adhere strictly to the established lab procedures and protocols.
6. Safety Equipment: Know the locations of safety showers, eyewash stations, fire extinguishers, and first aid kits.
7. Report Incidents: Immediately report accidents, spills, or any equipment malfunction to the lab supervisor.

**Mechanical Lab Precautions:**

1. Tool Safety: Handle tools and equipment with care. Return them to their designated places after use.
2. Machine Safety: Follow proper procedures while operating machinery to prevent accidents.
3. Protective Gear: Wear appropriate personal protective equipment (PPE) such as gloves, helmets, or masks based on the task being performed.
4. Ventilation: Ensure adequate ventilation in the lab, especially when working with materials that produce fumes or gases.
5. Chemical Handling: Handle chemicals cautiously, following recommended storage, usage, and disposal guidelines.
6. Electrical Safety: Be aware of electrical hazards and use insulation, grounding, and proper wiring when working with electrical components.

**Additional Safety Measures:**

1. Emergency Procedures: Understand evacuation plans and emergency procedures in case of fire, chemical spills, or other emergencies.
2. Labeling: Clearly label all containers with the contents, date, and any hazards they pose.
3. Workspace Cleanliness: Keep workspaces tidy to minimize potential hazards and allow for clear movement.
4. No Unauthorized Experiments: Avoid conducting experiments without proper approval or supervision.

**Protocols for Specific Experiments:**

1. Risk Assessment: Conduct a thorough risk assessment before starting any experiment and implement necessary safety measures.
2. Supervision: Ensure experiments are supervised by experienced personnel, especially when dealing with high-risk procedures or equipment.

# EXPERIMENT - 1

## AIM OF THE EXPERIMENT: -

To study about two stroke and four stroke petrol and diesel engine models.

## APPARATUS REQUIRED: -

SL. NO.	NAME OF THE APPARATUS	SPECIFICATION	QUANTITY
01	Model of petrol engine	2-stroke	1
02	Model of petrol engine	4-stroke	1
03	Model of diesel engine	2 stroke	1
04	Model of diesel engine	4 stroke	1

## THEORY: -

### ***TWO STROKE PETROL ENGINE***

- A two stroke cycle petrol engine was devised by Dug lad clerk in 1880.
- In this cycle, the suction, compression, expansion, and exhaust takes place during two strokes of the piston. It means that there is one working stroke after every revolution of the crank shaft.
- A two stroke engine has ports instead of valves.
- The four stages of a two stroke petrol engine are described below:

#### **1. SUCTION STAGE: -**

- In this stage, the piston, while going down towards BDC, uncovers both the transfer port and the exhaust port.
- The fresh fuel-air mixture flows into the engine cylinder from the crank case.

#### **2. COMPRESSION STAGE: -**

- In this stage, the piston, while moving up, first covers the transfer port.
- After that the fuel is compressed as the piston moves upwards BDC to TDC.
- In this stage, the inlet port opens and fresh fuel-air mixture enters into the crank case.

### 3. EXPANSION STROKE: -

- Shortly before the piston reaches the TDC (during compression stroke) the charge is ignited with the help of a spark plug.
- It suddenly increases the pressure and temperature of the product of combustion. But the volume, practically remains constant.
- Due to rise in the pressure, the piston is pushed downwards with a great force.
- The hot burnt gases expand due to high speed of the piston. During this expansion, some of the heat energy produced is transformed into mechanical work.

### 4. EXHAUST STROKE: -

- In this stage, the exhaust port is opened as the piston moves downwards.
- The product of combustion, from the engine cylinder is exhausted through the exhaust port into the atmosphere.
- This completes the cycle and the engine cylinders ready to suck the charge again.

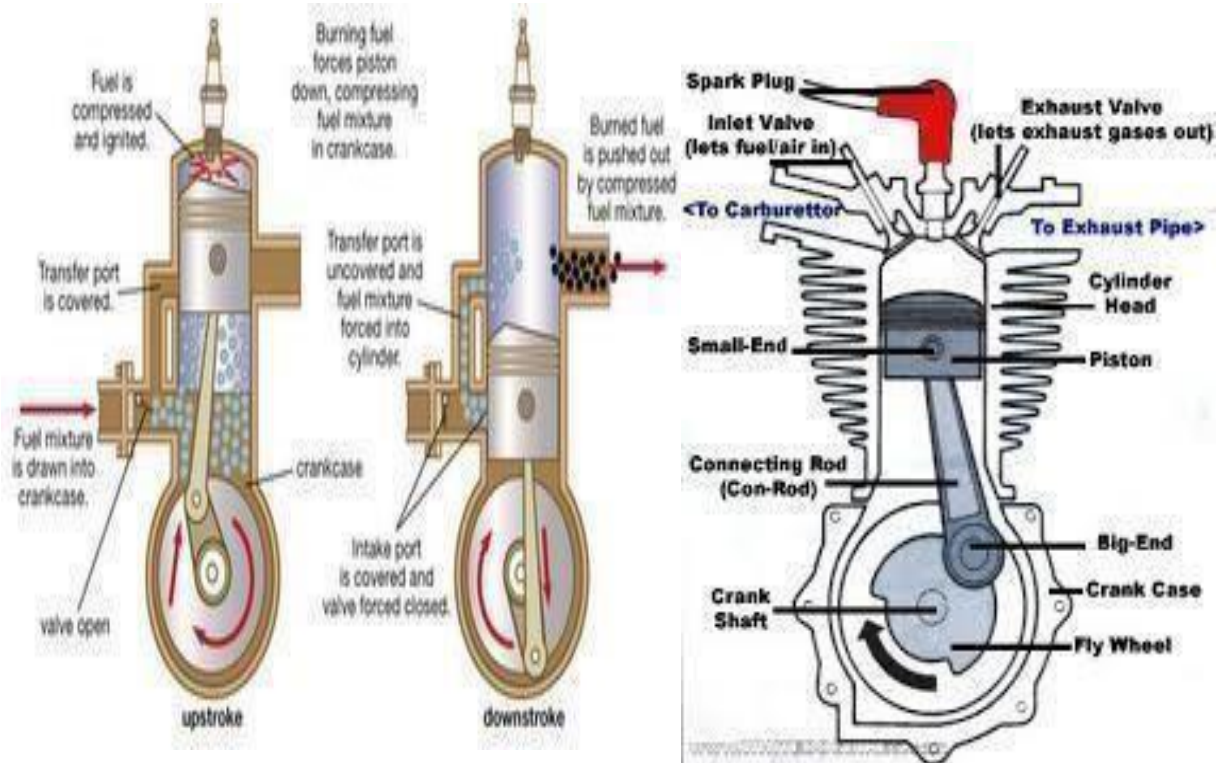

## ***FOUR STROKE PETROL ENGINE: -***

- It requires four strokes of the piston to complete one cycle of operation in the engine cylinder.
- The four strokes of a petrol engine are described below:

### **1. SUCTION STROKE: -**

- In this stroke, the inlet valve opens and the charge is sucked into the cylinder as the piston moves downward from TDC.
- It continues till the piston reaches its BDC.

### **2. COMPRESSION STROKE: -**

- In this stroke, both the inlet and exhaust valves are closed and the charge is compressed as the piston moves upwards from BDC to TDC.
- As a result of compression, the pressure and temperature of the charge increases considerably.
- This completes one revolution of the crank shaft.

### **3. EXPANSION STROKE: -**

- Shortly before the piston reaches TDC (during compression stroke), the charge is ignited with the help of a spark plug.
- It suddenly increases the pressure and temperature of the products of combustion but the volume, practically remains constant.
- Due to the rise in pressure, the piston is pushed down with a great force. The hot burnt gases expand due to high speed of the piston.
- During this expansion, some of the heat energy produced is transformed into mechanical work.

### **4. EXHAUST STROKE: -**

- In this stroke, the exhaust valve is open as piston moves from BDC to TDC.
- This movement of the piston pushes out the products of combustion, from the engine cylinder and is exhausted through the exhaust valve into the atmosphere.
- This completes the cycle, and the engine cylinder is ready to suck the charge again.



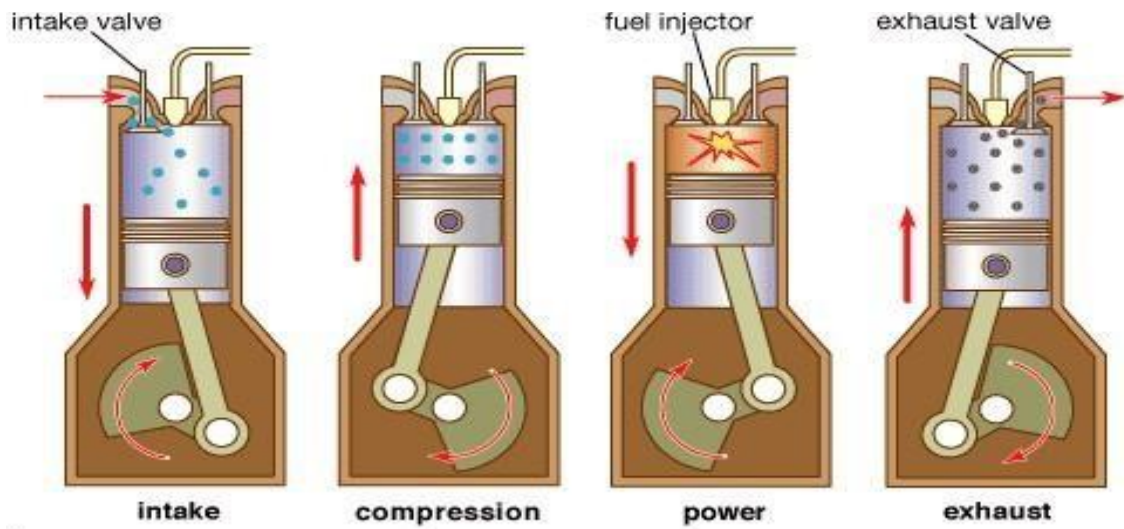

© 2007 Encyclopædia Britannica, Inc.

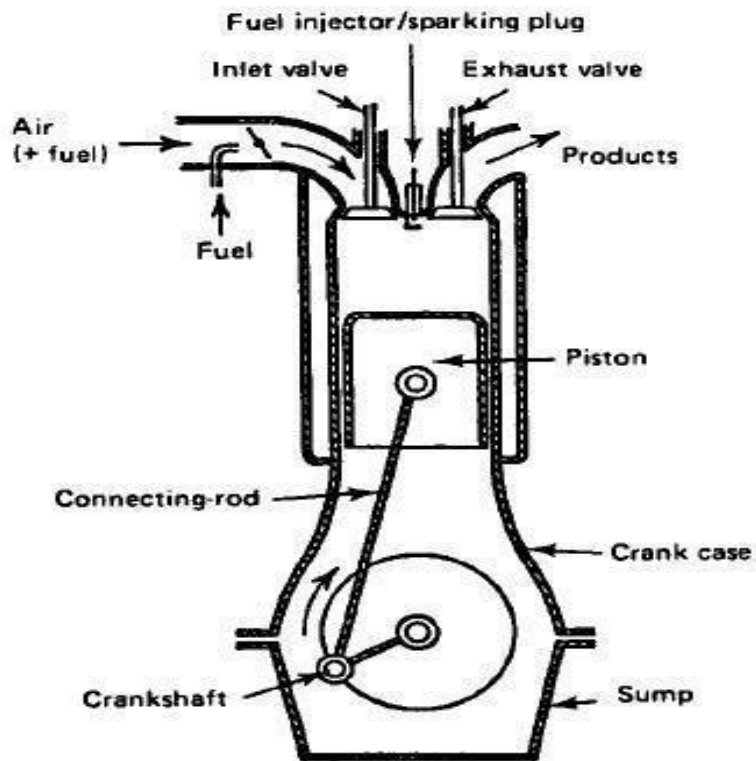

*4- Stroke Petrol Engine*

## TWO STROKE DIESEL ENGINE: -

- A two stroke diesel engine also has one working stroke after revolution of the crank shaft.
- All the four stages of a two stroke cycle diesel engine are described below:

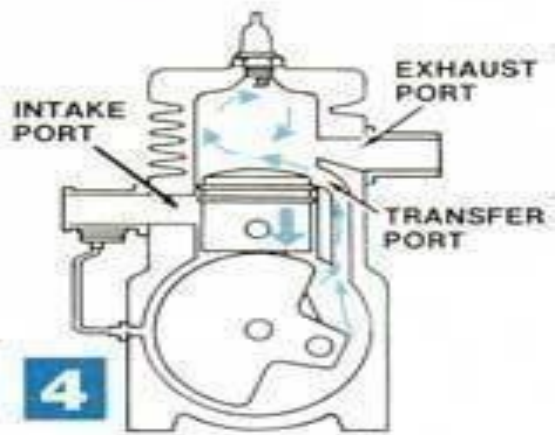
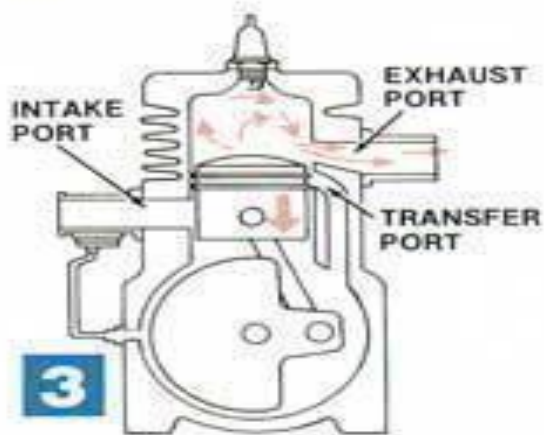
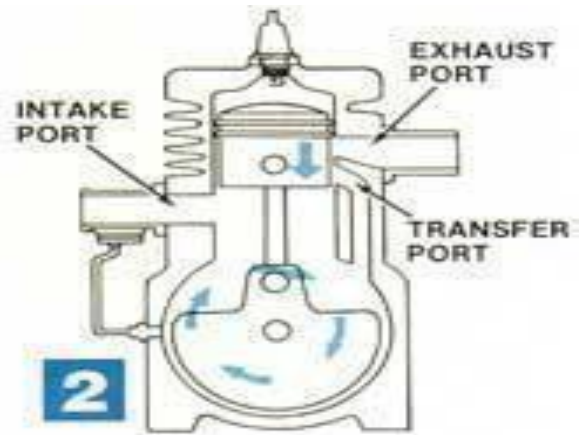
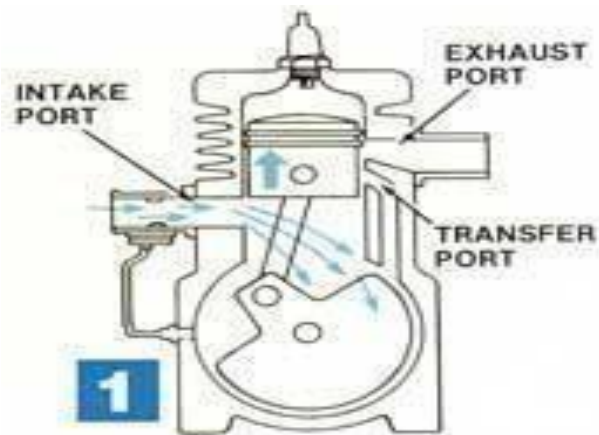
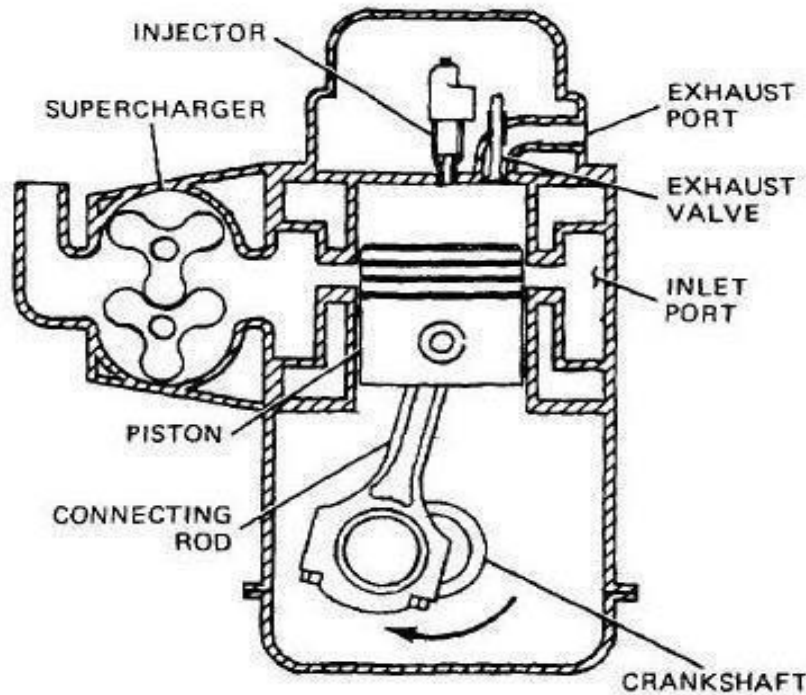

### **1. SUCTION STAGE: -**

- In this stage, the piston while going down towards BDC uncovers the transfer port and the exhaust port.
- The fresh air flows into the engine cylinder from the crank case.

### **2. COMPRESSION STAGE: -**

- In this stage, the piston while moving up, first covers the transfer port and then exhausts post.
- After that the air is compressed as the piston moves upward.
- In this stage, the inlet port opens and the fresh air enters in the crank case.

### **3. EXPANSION STAGE: -**

- Shortly before the piston reaches the TDC (during compression stroke), the fuel oil is injected in the form of very fine spray into the engine cylinder through the nozzle known as fuel injection valve.
- At this moment, temperature of the compressed air is sufficiently high to ignite the fuel. It suddenly increases the pressure and temperature of the products of combustion.
- Due to increase in pressure, the piston is pushed with a great force. The hot burnt gases expand due to high speed of the piston.
- During the expansion, some of the heat energy produced is transformed into mechanical work.
- 

### **4. EXHAUST STAGE: -**

- In this stage, the exhaust port is opened and the piston moves downwards.
- The product of combustion from the engine cylinder is exhausted through the exhaust port into the atmosphere.
- This completes the cycle, and the engine cylinder is ready to suck the air again.

### ***FOUR STROKE DIESEL ENGINE: -***

- It is also known compression ignition engine because the ignition takes place due to the heat produced in the engine cylinder at the end of compression stroke.
- The four strokes of the diesel engine are described below:

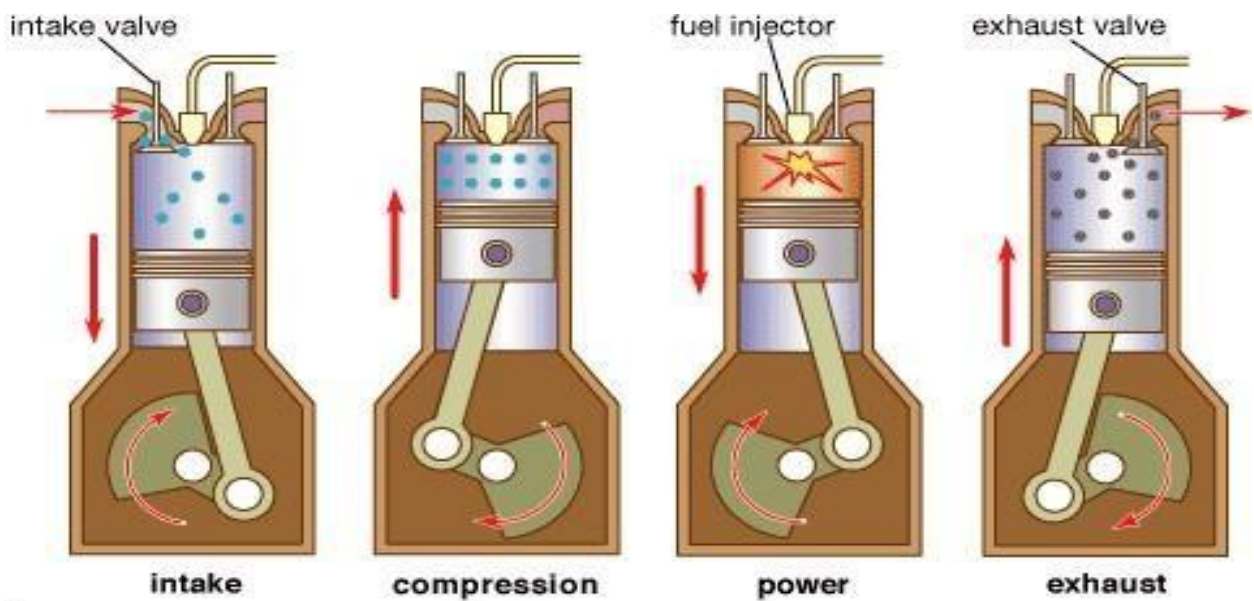
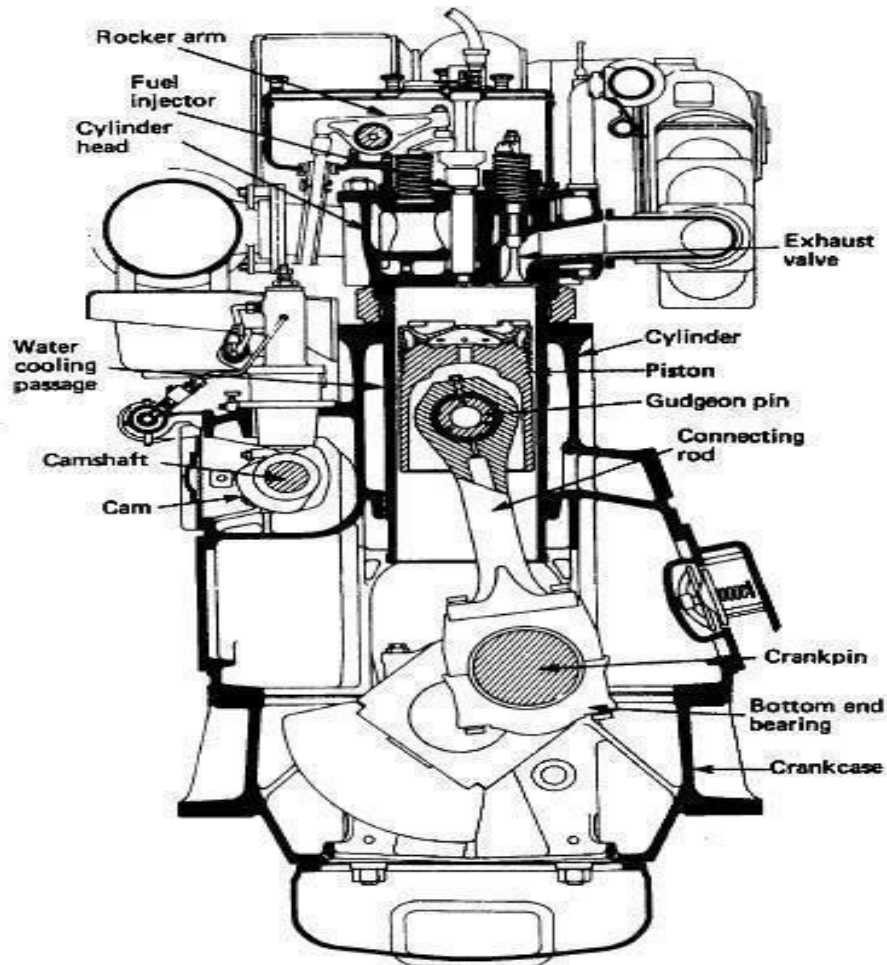

© 2007 Encyclopædia Britannica, Inc.

*4 stroke diesel engine*

### **1. SUCTION STROKE: -**

- In this stroke, the inlet valve opens and the pure air is sucked into the cylinder as the piston moves downwards from TDC.
- It continues till the piston reaches in the BDC.

### **2. COMPRESSION STROKE: -**

- In this stroke, both the valves are closed and the air is compressed as the piston moves upwards from BDC to TDC.
- As result of compression, pressure and temperature of the air increases considerably.
- This completes the revolution of the crank shaft.

### **3. EXPANSION STROKE: -**

- Shortly before the piston reaches the TDC, fuel is injected in the form of very fine spray in to the engine cylinder through the nozzle known as fuel injector or fuel injection valve.
- At this moment, temperature of the compressed air is sufficiently high to ignite the fuel. It suddenly increases the pressure and temperature of product of combustion.
- Due to increased pressure, the piston is pushed down with a great force. The hot burnt gases expand due to high speed of the piston.
- During the expansion, some of heat energy is transformed into mechanical work.

### **4. EXHAUST STROKE: -**

- In this stroke the exhaust valve is open as the piston moves from BDC to TDC.
- This movement of the piston pushes out the product of combustion from the engine cylinder through the exhaust valve into the atmosphere.
- This completes the cycle and the engine cylinder is ready to suck the fresh air again.

### **CONCLUSION: -**

From the above experiment we have successfully studied about the two stroke and four stroke petrol and diesel engine.

## **POST LAB QUESTION:**

1. What are the different stages in two stroke petrolengine?
2. What are the different stages in two stroke diesel engine?
3. What are the different stages in four stroke petrolengine?
4. What are the different stages in four stroke diesel engine?
5. Define stroke.
6. What is the function of spark plug?
7. What is the function of fuel injector?
8. What is the function of inlet and outlet valve?
9. Define piston speed.
10. What is the function of transfer port?

## EXPERIMENT - 2

### AIM OF THE EXPERIMENT: -

To determine the brake thermal efficiency of the single cylinder petrol engine.

### OBJECTIVE: -

After performing this experiment, students will be able to:

- Know about single cylinder petrol engine.
- Know about BHP, IHP & BSFC.
- Know how to calculate the performance of single cylinder petrol engine.

### APPARATUS REQUIRED: -

SL. NO.	EQUIPMENT	SPECIFICATION	
		Make	Honda
		Bhp	3HP
		Speed	3000RPM
		no of cylinder	1
		compression ratio	7.4:1
1	SINGLE CYLINDER PETROL ENGINE	Bore	57mm
		Stroke	57mm
		orifice dia	20mm
		ignition type	spark ignition
		types of cooling	Air cooled
		types of loading	hydraulic loading
		types of starting	Kick starting

### THEORY: -

#### **LOADING SYSTEM:**

- The engine test rig is directly coupled to a hydraulic dynamometer which is loaded by water flow into the dynamometer at  $0.5\text{kg/cm}^2$  constant head pressure. the load can be varied by

operating gate valve provided on the inlet line of the dynamometer.



- A breather valve is provided at the bottom of dynamometer which is to be kept crack opened throughout working range. the outlet will be connected to a valve to be adjusted depending upon the load conditions.

**DIAGRAM:**

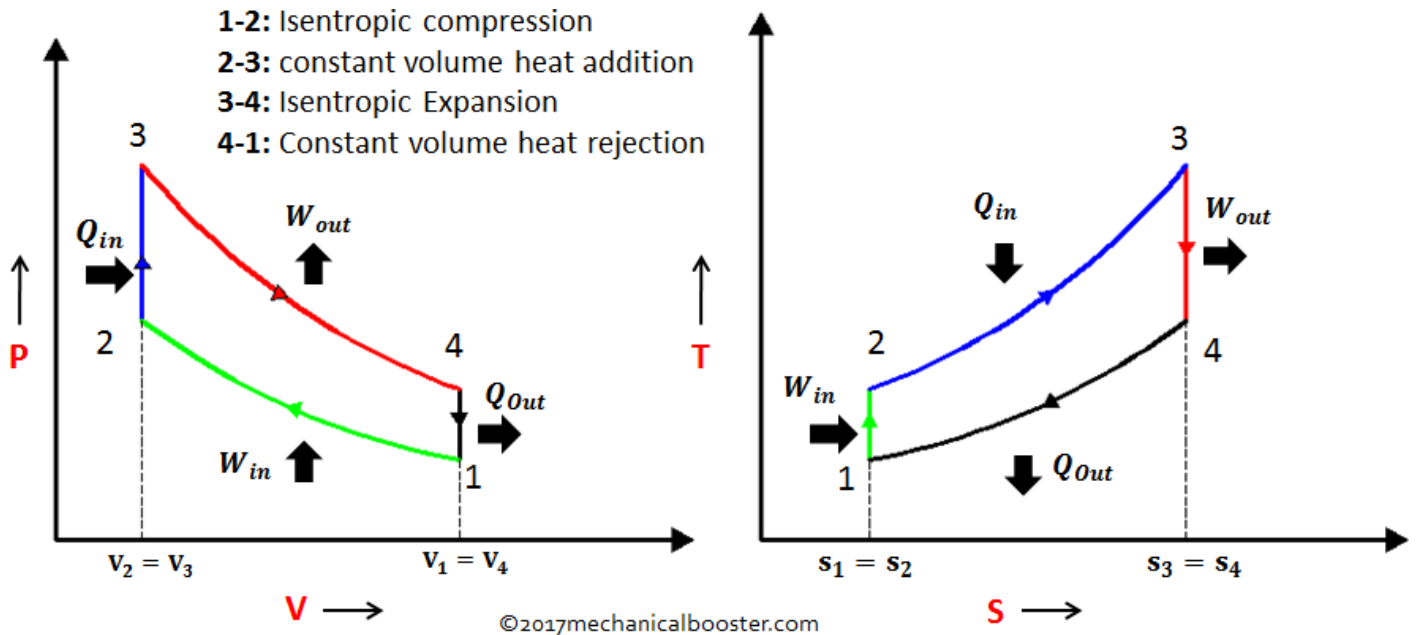

**P-V and T-S Diagram of Otto Cycle**

**PROCEDURE: -**

1. Connect the inlet of the engine jacket, calorimeter, and hydraulic dynamometer to a 0.5 kg/cm<sup>2</sup> constant head water source.
2. Open the inlet gate valves of the engine jacket and calorimeter to suitable desired flow rate.
3. Connect the instrumentation power input plug to a 230V single phase power source. Now all the digital meters, rpm, fuel weight and flow rate, air flow and temperature indicator display the respective readings.
4. Fill the fuel tank with commercial grade petrol mixed with SAE40 oil in 20:1 ratio.
5. Start the engine using the kickstarter provided with keeping the throttle lever slightly open.
6. Adjust the throttle lever till 3000 RPM is reached.

7. Now open the dynamometer inlet gate valve gradually to load the engine through hydraulic dynamometer. The load is indicated on a dial type spring balance in terms of kgs. The dynamometer arm having the length of  $r=0.2\text{m}$  gives the torque,  $T$ .

$$T=r*s$$

Where,  $s$  is the load indicated on the spring balance.

8. Operate the inlet gate valve of the dynamometer and set the load (0.9kg+spring balance error if any).

9. Allow the engine to run at the set load with the speed for few minutes.

10. Note down all the required parameters mentioned below.

- i) Speed of the engine (N) from digital RPM indicator.
- ii) Load(s) from spring balance.
- iii) Fuel consumption from digital fuel indicator in kg/hr.
- iv) Quantity of air from digital air flow meter.
- v) Temperatures from digital temperature indicator.
- vi) Water flow rate for calorimeter through the rotameter.

11. Repeat step 7 and 8 and increase the load and take a set of reading for

- i)  $\frac{1}{2}$  load (1.8kg+ spring balance error if any)
- ii)  $\frac{3}{4}$  load (2.7kg+ spring balance error if any)
- iii) Full load (3.6kg+ spring balance error if any)
- iv) Over load (4kg+ spring balance error if any)

12. With the above parameters the calculations are obtained.

### CALCUATION: -

$$BHP = \frac{2\pi NT}{4500} \text{ HP}$$

Where,  $N = \text{RPM}$

$T = \text{Torque}$

Brake thermal efficiency is given by

$$\text{Brake Thermal Efficiency} = \frac{BHP \times 4500 \times 60}{427 \times C_v \times w_f} \times 100$$

Where,  $C_v = \text{Calorific value of fuel} = 10500 \text{ Kcal/kg}$

$w_f = \text{Weight of fuel consumed.}$

## **CONCLUSION: -**

The brake thermal efficiency of single cylinder petrol engine is found to be .

## **POST LAB QUESTIONS: -**

- i) Explain the working of petrol engine.
- ii) Draw P-V & T-S diagram of petrol engine.
- iii) Which device is used to measure the brakepower?
- iv) State different strokes of petrol engine.
- v) What type of loading is taken in this experiment?
- vi) Define brake thermal efficiency.

## EXPERIMENT - 3

### AIM OF THE EXPERIMENT: -

To determine the brake thermal efficiency of the single cylinder diesel engine.

### OBJECTIVE: -

After performing this experiment student will be able to:

- Know about single cylinder diesel engine.
- Find the brake thermal efficiency of the single cylinder diesel engine

### APPARATUS REQUIRED: -

SL. NO.	EQUIPMENT	ENGINE SPECIFICATION	
		Make	Honda
		BHP	5
		Speed	1500 RPM
		No. of Cylinder	One
		Compression Ratio	16.5:1
01	Single Cylinder Diesel Engine Test Rig	Bore	80mm
		Stroke	110mm
		Orifice Dia	17mm
		Type of Ignition	Compression Ignition
		Method of Loading	Rope brake
		Method of Starting	Crank Start
		Method of Cooling	Water

### THEORY: -

Diesel engine use diesel as the working fluid. Here high compression ratio of the fuel ignites the fuel. Diesel cycle consist of four different stages i.e suction, compression, expansion and exhaust. Here only air which is sucked in the suction stroke is compressed in the compression stroke. Then fuel from the fuel injector enters in to the engine cylinder at the end of compression and combustion of fuel takes place. After combustion, in the exhaust stroke, the burnt out gases escapes from the engine cylinder.

## **BRAKE THERMAL EFFICIENCY:**

Brake thermal efficiency is the ratio of energy in the brake power (BP) to the input fuel energy in appropriate units.

### **DIAGRAM:**

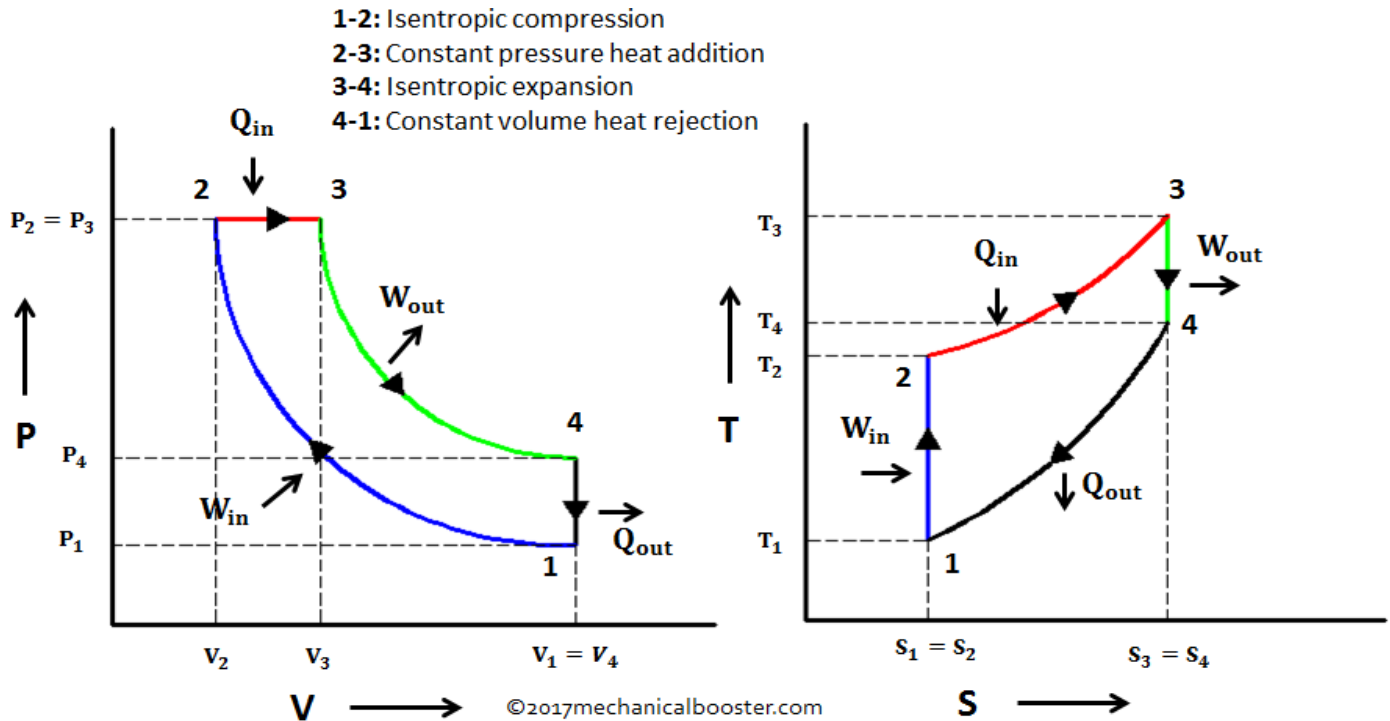

**P-V and T-S Diagram of Diesel Cycle**

### **PROCEDURE: -**

1. Fill fuel into the fuel tank mounted on the panelframe.
2. Check the lubricating oil in the engine sump with the help of dipstick provided.
3. Open the fuel lock provided under the fuel tank and ensure that no air is trapped in the fuel line connecting fuel tank and engine.
4. De-compress the engine by decompression lever provided on the top of the engine head. (Lift the lever for decompression)
5. Crank the engine slowly, with the help of handle provided, and ascertain proper flow of fuel into the pump and in turn through the nozzle into the engine cylinder.

6. When maximum cranking speed is attained, pull the decompression lever down, now. The engine starts. Allow the engine to run and stabilize. (Approximately 1500 RPM. The engine is a constant speed engine fitted with centrifugal governor)
7. Now load the engine by placing the necessary dead weights on the weighing hanger, to load the engine in steps of 1/4, 1/2, 3/4, full and 10% over load. Allow the engine to stabilize on every load change.
8. Record the following parameters indicated on the panel instruments on each load step.
  - A) Speed of the engine from RPM indicator.
  - B) Rate of fuel from burette.
9. Exact load in kg ( $W$ ) on the engine by adding the amount of weight added on the pan in kg ( $W_1$ ) plus weight of pan in kg ( $W_2$ ) minus spring balance reading in kg ( $W_3$ )
10. To stop the engine after the experiment is over push/pull the governor lever towards the engine cranking side.

### **CALCULATION: -**

In this experiment, we have to calculate the brake thermal efficiency of the Single Cylinder Four Stroke Diesel engine:

$$B. P = \frac{\pi N(W - S)(D + d)}{60 \times 1000} \text{ KW}$$

where,  $W$  = Dead Weight in N,  
 $S$  = Spring Balance reading in N,  
 $D$  = Diameter of Brake drum in meter,  
 $d$  = Diameter of rope in meter  
 $N$  = Speed of the engine

$$\text{Brake Thermal Efficiency} = \frac{\text{Brake Power}}{\text{Energy supplied to the engine}}$$

$$\eta_{Bth} = \frac{B. P}{m_f \times C_v}$$

where,  $C_v$  = Calorific value of fuel (Diesel) = 46200 kJ/kg  
 Density of petroleum diesel = 850.8 kg/m<sup>3</sup>

## **CONCLUSION: -**

The brake thermal efficiency of single cylinder diesel engine is found to be .

## **POST LAB QUESTIONS: -**

1. Explain the working of Diesel engine.
2. Draw P-V & T-S diagram of Diesel engine.
3. State different strokes of Diesel engine.
4. Define brake thermal efficiency.

# EXPERIMENT – 4

## AIM OF THE EXPERIMENT: -

Determine the B.H.P, I.H.P and BSFC of multi cylinder engine by Morse test.

## OBJECTIVE: -

After performing this experiment student will be able to understand:

- i) Why morse test is required?
- ii) What is BHP, IHP & BSFC?

## APPARATUS REQUIRED: -

SL. NO.	EQUIPMENT	SPECIFICATION
		BHP 10
		Speed 1500 RPM
		No of cylinder 4
		Compression Ratio 7.8: 1
01	Four cylinders Petrol Engine Test Rig.	Bore 68 mm
		Stroke 75 mm
		Orifice Dia 20mm
		Type of ignition Spark Ignition
		Type of cooling Water Cooling
		Type of loading hydraulic Loading
		Type of starting Self Starting

## THEORY: -

- The Morse test is used to find out the indicated power of a multi cylinder reciprocating engine.
- The engine is run at a particular speed and the torque is measured by cutting out the firing of each cylinder in turn and noting the fall in brake power each time while maintaining the set engine speed by reducing load.
- The observed difference in brake power between all cylinder firing and with one cylinder cut out is the indicated power of the cut out cylinder.



## PROCEDURE: -

1. Connect the water inlets of the engine jacket calorimeter and hydraulic dynamometer to a 0.5 kg/cm<sup>2</sup> constant head water source.
2. Open the inlet gate valves of the engine jacket and calorimeter to suitable desired flow rate.
3. Connect the battery terminals to a well charged 12V battery with the terminals marked “+” and “-” respectively to the engine cable terminals.
4. Connect the instrumentation power input plug to a 230V single phase power supply. Now all the digital meters namely rpm, fuel weight and flow rate and air flow rate and temperature indicator display the respective readings.
5. Fill up petrol into the petrol tank provided mounted on a 5kg capacity load cell until the fuel weight meter reads approximately 4000gms.
6. Open the petrol cock provided underneath the petrol tank and ensure all the knife switches provided for the morse test are in engaged position. Also ensure the accelerator knob is in off position.
7. Insert the ignition key into the starter switch and turn it clock wise to hear a click sound by which the negative deflection will be shown at the bottom of the panel. Turn the key further clockwise to start the engine. Now the engine is running at idle speed (600- 800) on the digital rpm indicator. Ensure the oil pressure gauge reads 2kg/cm<sup>2</sup> to 3kg/cm<sup>2</sup>.
8. Increase the speed by turning the accelerator knob clockwise until the rpm indicator reads 1500 rpm.
9. Now open the dynamometer inlet gate valve to load the engine through hydraulic dynamometer. The load is indicated on a dial type spring balance in terms of kgs. the dynamometer arm having a length of  $r=0.32\text{m}$  gives the torque.
10. Load the engine to full load at rated speed. Allow it to run for few minutes cut off the power to one cylinder by pulling the knife switch provided on the engine panel. Now the engine is running on 3 cylinders only. As a result, the speed of the engine drops down by operating the water inlet valve to reduce the load slowly so that the speed of the engine comes back to its rated speed (1500rpm). Record the spring balance reading.
11. Pull out the next knife switch immediately and observe the engine speed.

## CALCULATION: -

$$BHP = \frac{2\pi NT}{4500} \text{ HP}$$

Let W = Dynamometer load in Kg

N = RPM of the engine

B = BHP of 4 cylinder

IHP = Indicated horse power

BHP = Brake horse power

B1 = BHP of 3 cylinder when 1st is cut off

B2 = BHP of 3 cylinder when 2<sup>nd</sup> is cut off

B3 = BHP of 3 cylinder when 3<sup>rd</sup> is cut off

B4 = BHP of 3 cylinder when 4<sup>th</sup> is cut off

### IHP Calculation:

IHP of 1<sup>st</sup> cylinder = B-B1

IHP of 2<sup>nd</sup> cylinder = B-B2

IHP of 3<sup>rd</sup> cylinder = B-B3

IHP of 4<sup>th</sup> cylinder = B-B4

### Total IHP Calculation:

Total IHP of the engine = IHP (1<sup>st</sup> + 2<sup>nd</sup> + 3<sup>rd</sup> + 4<sup>th</sup>)

### BSFC Calculation:

It is the ration between the mass of fuel consumed per hour to the BHP.

$$B.S.F.C = \frac{m_f}{BHP} \text{ kg/BHP. hr}$$

where  $m_f$  = Fuel consumed in kg/hr

### TABULATION: -

SL. NO.	CONDITION	N (rpm)	W (kg)	BHP	IHP	BSF C
1	A	1500				
2	B	1500				
3	C	1500				
4	D	1500				

## **CONCLUSION: -**

The B.H.P, I.H.P and BSFC of multi cylinder engine was found out to be .

## **POST LAB QUESTIONS: -**

- i) Define BHP?
- ii) Define IHP?
- iii) Define BSFC?
- iv) What is the purpose of conducting morse test?

# EXPERIMENT – 5

## AIM OF THE EXPERIMENT: -

To determine the mechanical efficiency of a two stage air compressor.

## OBJECTIVE: -

After performing this experiment student will be able to understand:

- i) About air compressor.
- ii) Different components and working of air compressor.

## APPARATUS REQUIRED: -

SL.NO.	EQUIPMENT	SPECIFICATION	QUANTITY
01	Air compressor test rig		01
02	Tachometer		01
03	Stop watch		01

## THEORY: -

An air compressor is the machine which compresses the air and to raise its pressure. The air compressor sucks air from atmosphere, compresses it and then delivers the same under a high pressure to a storage vessel. From the storage vessel, it may be conveyed by the pipe line to a place where the supply of compressed air is required, since the compression of air requires some work to be done on it. Therefore, a compressor must be driven by some prime mover.

## CONSTRUCTION:

An air compressor consists of the following components:

1. Cylinder
2. Piston
3. Inlet valve
4. Outlet valve
5. Pressure gauge
6. Pressure vessel

## WORKING PROCEDURE:

- When the piston moves downward the pressure inside the cylinder falls below the atmospheric pressure.
- Due to this pressure difference the I.V. gets opened and the air is sucked into the cylinder.
- Now when the piston moves upward the pressure inside the cylinder goes on increasing till it reaches the discharge pressure. At this stage the discharge valve gets opened and air is delivered to the container.
- At the end of delivery stroke a small quantity of air at high pressure is left in the clearance space. As the piston start its suction stroke, the air contained in the clearance space expands till pressure reaches upto the required limit.
- At this stage the inlet valve gets opened as a result of which fresh air is sucked into the cylinder and the cycle is repeated.

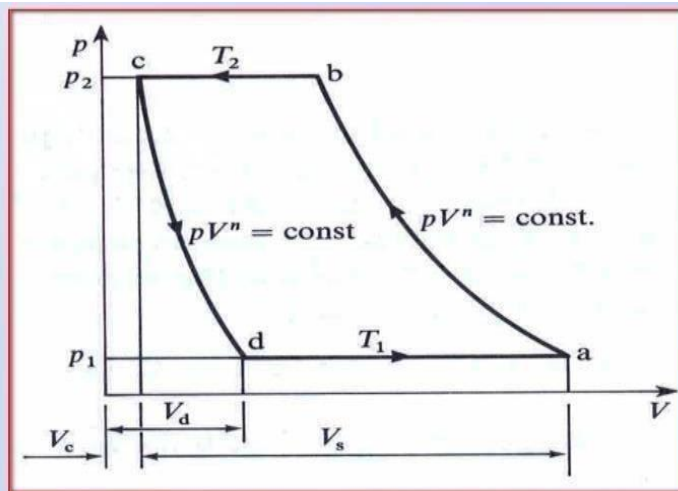

**Indicator diagram for a reciprocating compressor**

## CALCULATION: -

Mechanical efficiency of compressor,

$$\eta_{mech} = \frac{I.P}{B.P}$$

$$I.P = \frac{W \times N}{60 \times 1000} \text{ kW}$$

Work done by the compressor,

$$W = \frac{n}{n-1} mRT_1 \left\{ \left( \frac{p_2}{p_1} \right)^{\frac{n}{n-1}} - 1 \right\}$$

$$B.P = \frac{W \times N}{2000} \text{ kW}$$

where  $W$  = Work done

$N$  = Number of revolution in RPM

$P_1$  = Pressure of air at the inlet of the compressor

$P_2$  = Pressure of the air at the outlet of the compression

$T_1$  = Absolute temp. of air the inlet of the compressor

$T_2$  = Absolute temp. of air the outlet of the compressor

### TABULATION: -

SL. NO.	P1	P2	T1	T2	I.P	B.P	MECH EFFICIENCY
1							
2							
3							

### CONCLUSION: -

The mechanical efficiency of a two stage air compressor was found to be .

### PRECAUTION: -

- i) Handle the set up carefully.
- i) Before Starting the setup check all connections are tight.
- ii) Wear safety shoes.
- iii) Follow the instructions properly.

### POST LAB QUESTION: -

- i) What is multistage air compressor?
- ii) What is the need of intercooler in air compressor?
- iii) Define mechanical efficiency of air compressor?

iv) Draw the P-V diagram of single stage air compressor.

# EXPERIMENT – 6

## AIM OF THE EXPERIMENT: -

Study of pressure measuring devices like Manometer & Bourdon tube pressure gauge.

## APPARATUS REQUIRED: -

SL.NO.	EQUIPMENT	SPECIFICATION	QUANTITY
01	Manometer	U-tube	01
02	Bourdon tube pressure gauge		01

## THEORY: -

### **MANOMETER:**

- A Manometer is slightly improved form of a piezometer tube for measuring high as well as negative pressure.
- A simple manometer, in its simplest form, consists of a tube bent in U-shape, one end of which is connected to the vessel containing the liquid whose intensity of pressure is to be measured and other end is open to the atmosphere.
- The liquid used in the bent tube is generally Mercury (Hg) which is 13.6 times heavier than water.
- The pressure of the liquid containing in the vessel will force the manometric liquid in the left hand vertical limb of the U-tube downward and will force the manometric liquid to rise up in the right hand vertical limb of the U-tube through equal distance. This will happen when the pressure in the vessel is greater than atmospheric pressure.
- If pressure of liquid in the vessel is less than atmospheric pressure, the deflection of manometric liquid will be observed in the left hand limb of the u-tube.
- Since below the surface A-B, the liquid is homogenous and since the liquid is at rest, the pressure along the plane A-B in the left hand limb of the U-tube is equal to the pressure in the right hand limb of the U-tube along the plane A-B.
- Then by measuring the difference in mercury level above line A-B, and equating the pressure at A and pressure at B we can measure pressure of liquid flowing in the pipe.



## ***DIFFERENT TYPES OF MANOMETER:***

### **1. U-Tube Manometer:**

U-Tube manometer consists of a U – formed bent tube whose one end is hooked up to the gauge Location 'A' and alternative Location is receptive the atmosphere. it's then stuffed with a Liquid. The density of the Liquid dictates the vary of pressures that may be observed.

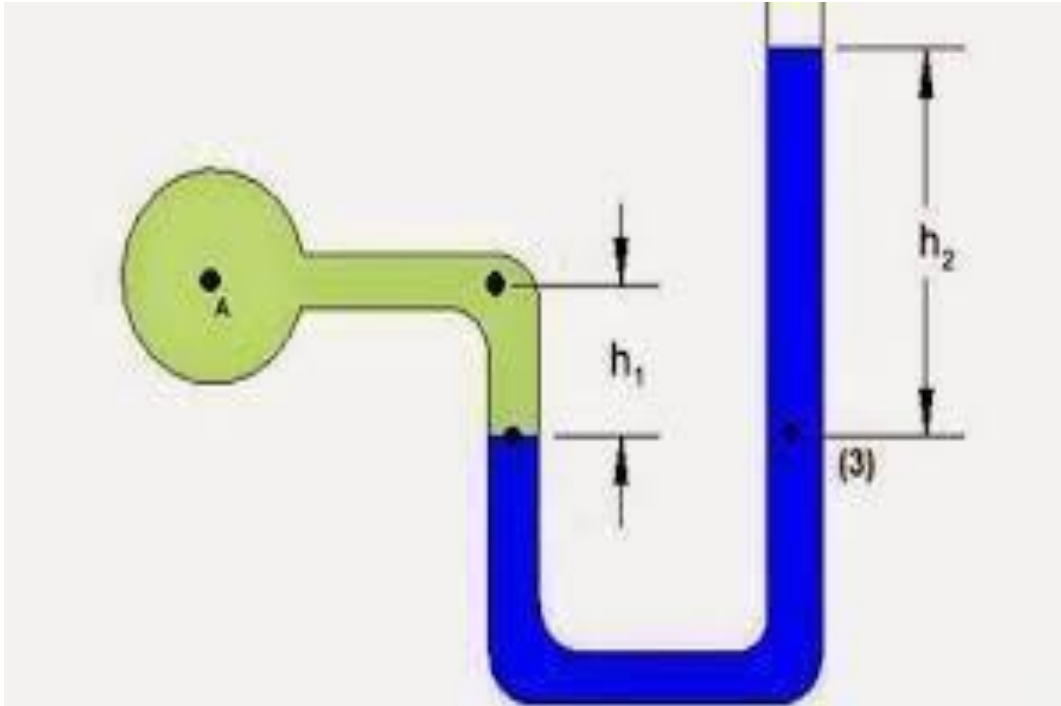

**U-TUBE MANOMETER**

### **2. Inverted U-Tube Manometer:**

Inverted U-Tube manometer is employed for the measuring of tiny pressure differences in liquids. It consists of associate inverted U – Tube containing a light-weight liquid. this is often used to observe the differences of low pressures between 2points wherever higher accuracy is needed. It typically consists of associate air cock at prime of Mano-metric Liquid kind.

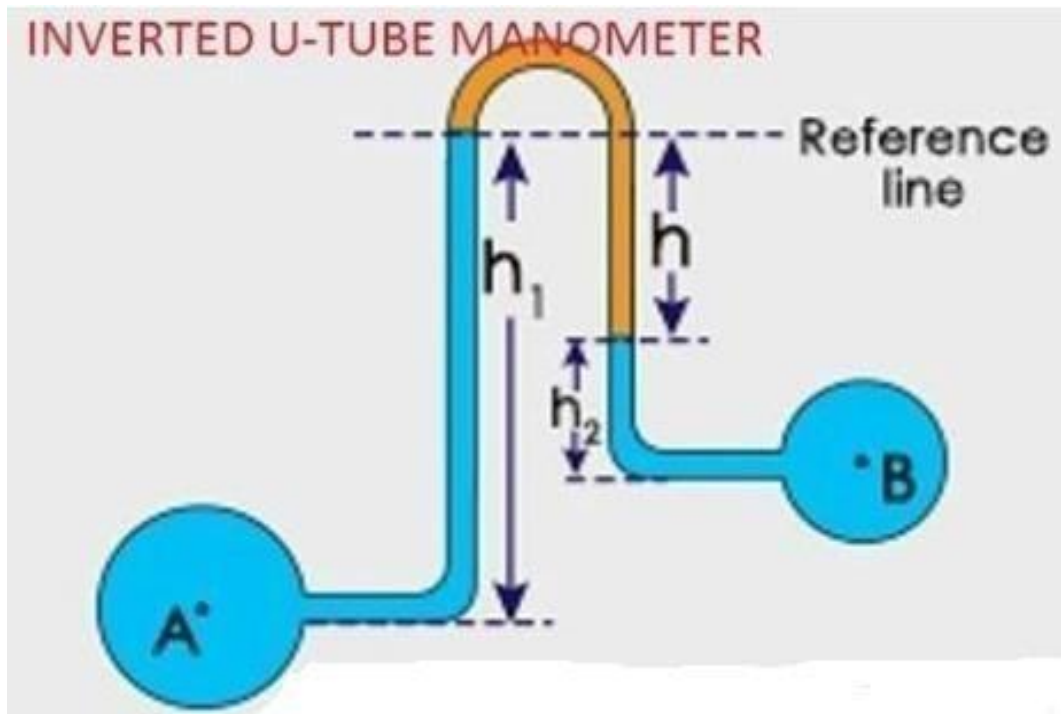

INVERTED U-TUBE MANOMETER

### 3. Differential U-Tube Manometer:

Differential U-tube manometer is extremely similar to the U-tube manometer. Here one open location (which was thought-about as atmospheric location in U-Tube manometer) is connected to a different pressure location. This manometer is largely used to observe the differences between to totally different points otherwise you will say we tend to calculate the difference.

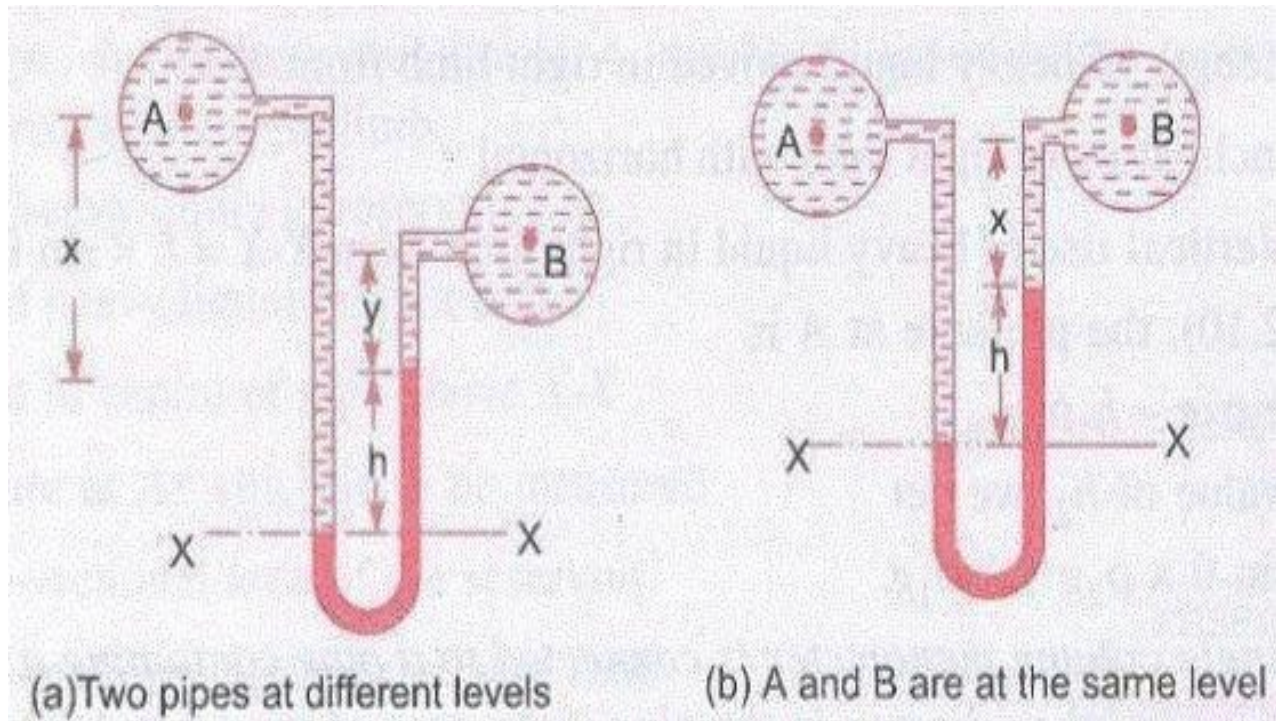

### DIFFERENTIAL MANOMETER

#### ***BOURDON TUBE PRESSURE GAUGE:***

- Bourdon pressure gauge consists of a circular spring tube A, called Bourdon tube.
- The Bourdon tube is made up of special quality bronze and oval in cross section.
- One end of the Bourdon tube is closed and connected to a link L and the other end is secured in a vertical tube B.
- The link L connects the closed end of the Bourdon tube to a toothed sector C which is hinged at O.
- The toothed sector C gears with a pinion D which is mounted on a central spindle carrying a pointer P.
- The pointer moves on a dial graduated in pressure unit (i.e. bar)
- The pressure gauge is connected to the vessel containing fluid under pressure.
- Due to fluid pressure in the Bourdon tube, it has tendency to achieve a circular shape. But before the tube can do so, it must be straightened itself.
- This tendency of straightening moves the free end of the Bourdon tube outwards.
- As a result, the toothed sector moves about the hinge O and causes the pinion D to rotate which, in turn moves the pointer F to move on a dial graduated in bar.
- The movement of the free end of the Bourdon tube is proportional to the difference

between the external atmospheric pressure and internal fluid pressure.

- Hence the pressure gauge records the gauge pressure which is the difference between fluid pressure and outside atmospheric pressure.

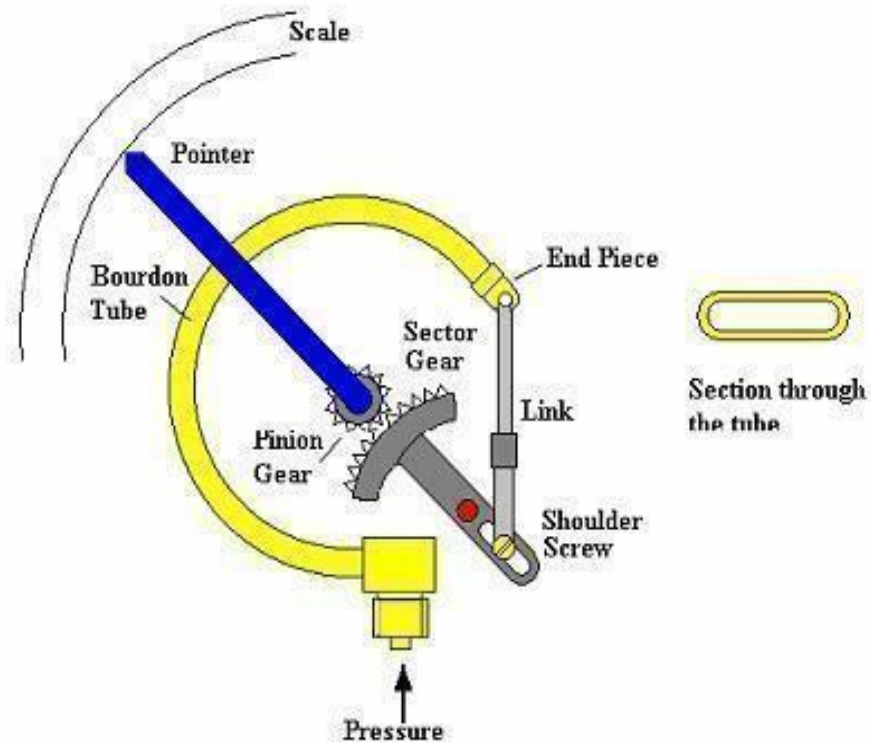

## CONCLUSION: -

Hence we successfully studied about Manometer and Bourdon tube pressure gauge.

# EXPERIMENT – 7

## AIM OF THE EXPERIMENT: -

Verification of Bernoulli's theorem.

## APPARATUS REQUIRED: -

SL NO	EQUIPMENTS	SPECIFICATION	QUANTITY
01	Bernoulli's Apparatus test rig		01
02	Stop watch	DIGITAL	01
03	Steel rule	30cm	01
04	Discharge tank	40 cm x 30 cm x 100 cm	01

## THEORY: -

Bernoulli's theorem states that "For a steady, continuous, incompressible, & non viscous fluid flow, the total energy or total head remains constant at all the sections along the fluid flow provided there is no loss or addition of energy".

i.e.-

$$\frac{p}{\rho g} + \frac{v^2}{2g} + Z = H = \text{Constant}$$

Where,  $p$  = Pressure head in m

$\frac{v^2}{2g}$  = Velocity or kinetic head in m (Velocity of water =  $Q$ , m/s)

$Z$  = Potential head (Height above some assumed datum level i.e. -  $Z=0$ )

Bernoulli's equation is based on Euler's equation of motion. It is applicable to flow of fluid through pipe and channel. It is required to be modified if the flow is compressible & unsteady.

## CONCEPT STRUCTURE: -

The pressure head at every gauge point depends upon the velocity at that cross section. If the cross section area of the conduit is more the velocity will be less and pressure head is more.

The values of pressure head of the first gauge point is more and subsequently decrease up to centre of gauge point. Again the pressure head increases and will form a parabolic curve.

## Steady State Condition

### Pressure Head

$$\left( \frac{p}{\rho g} \right)$$



### Kinetic Head

$$\left( \frac{v^2}{2g} \right)$$



### Potential head

$$(Z)$$

**TOTAL HEAD**

**CONSTANT**

### PROCEDURE: -

- i) Measure the area of conduit at various gauge points.
- ii) Open the supply valve and adjust the flow so that the water level in the inlet tank remains constant.
- iii) Measure the height of water level in the collecting tank by a piezometric tube with the help of steel rule.
- iv) Measure the discharge of the conduit with the help of measuring tank.
- v) Note the time duration by stop watch from beginning of initial flow to end of the flow
- vi) Repeat the step (i) to (v) for two more readings.

### TECHNICAL SPECIFICATION: -

Length of the discharge tank ( $L$ ) = 40cm = 0.4m

Breadth of the discharge tank ( $b$ ) = 30cm = 0.3m

Area of the measuring tank ( $A$ ) =  $L \times b = 0.4 \times 0.3 = 0.12 \text{ m}^2$

## OBSERVATION: -

Depth of water collected in discharge tank,  $h =$                       cm =                      m  
Volume of water collected in the tank,  $q = A \times h = 0.12 \text{ m}^2 \times$                       m<sup>3</sup>  
Time of collection ( $t$ ) =                      sec

## CALCULATION TABLE: -

Tube No.	Area of flow of tubes, $A$ (m <sup>2</sup> )	Discharge, $Q = q/t$ (m <sup>3</sup> /s)	Velocity of flow, $V$ (m/s) $V = Q/A$	Velocity Head, $V^2/2g$ (m)	Pressure Head, $P/\rho g$ (m)	Datum Head, $Z$ (m)	Total Head, $H = P/\rho g + V^2/2g + Z$ (m) (v +vi + vii)	Remark
(i)	(ii)	(iii)	(iv)	(v)	(vi)	(vii)	(viii)	(ix)
01								
02								
03								
04								
05								
06								
07								

## CONCLUSION: -

Hence we have successfully verified Bernoulli's Theorem and we see that the total head in all the sections of the Bernoulli's apparatus test rig (venturimeter) is constant. The slight variation if any is due to losses.

## POST LAB QUESTION: -

1. Define velocity head?
2. What are the practical applications of Bernoulli's equation?

## EXPERIMENT – 8

### AIM OF THE EXPERIMENT: -

Determination of the Co-efficient of Discharge ( $C_d$ ) from venturimeter.

### APPARATUS REQUIRED: -

SL. NO.	EQUIPMENT	SPECIFICATION	QUANTITY
01	Venturimeter test rig		01
02	Stop Watch	Digital	01
03	Steel Rule	L=30cm	01

### THEORY: -

A venturimeter is an instrument used to measure the rate of discharge at different sections of the pipe line. A venturimeter consists of 3-parts: -

- Converging section
- Throat section
- Divergent Section

$$\text{Co-efficient of discharge, } C_d = \frac{Q_{act}}{Q_{theo}}$$

$$\text{where, } Q_{act} = \frac{l \times b \times h}{t}$$

$l$  = length of discharge tank

$b$  = breadth of discharge tank

$h$  = height of of discharge tank

$t$  = time taken in sec

$$Q_{theo} = A_1 \times A_2 \times \sqrt{2gH}$$

$$\sqrt{A_1^2 - A_2^2}$$

$A_1$  = inlet area of venturimeter

$A_2$  = Outlet area of venturimeter

### PROCEDURE: -

1. Set the manometric pressure tube to atmospheric pressure by opening the upper valve



2. Now the supply of water may be controlled by the stop valve.

3. One of the valves of any pipe may be opened and close all of other three valves/pipes.
4. Note the discharge reading for the particular flow by measuring the height of the discharge tank.
5. Note the time taken by stop watch for the particular flow.
6. Note the reading for the pressure head from the U-tube manometer, with its corresponding reading of discharge.
7. Now take three readings for this pipe and calculate  $C_d$  for that instrument using formula given above.
8. Now close this valve and open another valve having different diameter pipe and repeat this procedure as mentioned above. Three such readings also taken and calculate  $C_d$ .
9. Similarly take readings for all other diameter pipe and calculate  $C_d$  in each case.

### **TECHNICAL SPECIFICATION: -**

Length of discharge tank,  $l = 40\text{cm} = 0.4\text{m}$ ,

Breadth of the discharge tank,  $b = 30\text{ cm} = 0.3\text{m}$

Height of discharge tank,  $h = 100\text{cm} = 0.10\text{m}$ ,

Inlet dia of Venturimeter,  $D_1 = 2\text{cm} = 0.02\text{m}$

Inlet Area ( $A_1$ ) =  $\pi/4 \times (D_1)^2 = \pi/4 \times (0.02)^2 =$   $\text{m}^2$

Outlet dia of Venturimeter,  $D_2 = 1\text{cm} = 0.01\text{m}$

Outlet Area ( $A_2$ ) =  $\pi/4 \times (D_2)^2 = \pi/4 \times (0.01)^2 =$   $\text{m}^2$

Specific gravity of mercury ( $S_g$ ) =  $\frac{\rho_{Hg}}{\rho_{H_2O}} = \frac{13600}{1000} = 13.6$

Specific gravity of mercury ( $S_o$ ) =  $\frac{\rho_{H_2O}}{\rho_{H_2O}} = \frac{1000}{1000} = 1$

$\rho_{H_2O} \quad 1000$

### **CALCULATION TABLE: -**

Sl No.	MANOMETER READING (m)		Net head ( $H$ )= $\frac{(h_1 - h_2)}{S_g}$	$Q_{act}$ ( $\text{m}^3/\text{sec}$ )	$Q_{theo}$ ( $\text{m}^3/\text{sec}$ )	$C_d = \frac{Q_{act}}{Q_{theo}}$	Remark
	Initial height, $h_1$	Final height, $h_2$					
01			$S_o - 1$				
02							
03							

**CONCLUSION: -**

From the above experiment, the Co-efficient of Discharge ( $C_d$ ) of venturimeter was found out to be .....

## EXPERIMENT – 9

### AIM OF THE EXPERIMENT: -

Determination of the  $C_c$ ,  $C_d$  and  $C_v$  from orificemeter.

### APPARATUS REQUIRED: -

SL.NO.	EQUIPMENT	SPECIFICATION	QUANTITY
01	Orifice Tank With Piezometer		01
02	Stop Watch	Digital	01
03	Collecting Tank		01

### THEORY: -

Orifices are devices used for discharging fluids into the atmosphere. It is the opening in the wall of a tank or in a plate which may be fitted in a pipe such that the plate is normal to the axis of the pipe. The discharging fluid from the tank/conduit through the orifice comes out in the form of a free jet. In the process, the total energy of the fluid in the tank is converted to kinetic energy as the jet issues out into the atmosphere. The jet cross section initially contracts to a minima and then expands partly due to the viscous resistance offered by the surrounding atmosphere and partly due to inertia of the fluid particles. The section which has the minimum area is known as 'vena contracta'. The contraction and expansion of the jet results in loss of energy.

The actual velocity at vena contracts is smaller than the theoretical velocity due to frictional resistances at the orifice edges. The ratio between the actual velocity and the theoretical velocity of the jet is known as coefficient of velocity  $C_v$ . Its value also depends upon the size and shape of the orifice and the head causing flow. The coefficient velocity for a vertical orifice is determined experimentally by measuring the horizontal and vertical coordinates of the issuing jet. The water flows through an orifice under a constant head  $H$ . Let  $V$  be the actual velocity (which is horizontal) of the jet. Obviously, while covering horizontal distance, the jet is acted upon by gravity with a downward acceleration ' $g$ '. Consider a small particle of water at vena contracts. Suppose it falls through a vertical distance ' $y$ ' in a horizontal distance  $x$ , in time  $t$  sec.

Then,

$$x = Vt \text{ and } y = \frac{1}{2}gt^2$$

Or

$$y = \frac{1}{2}gx^2$$

Or

$$V = \sqrt{2gx^2}$$

$2y$

But theoretical Velocity,

$$V_{theo} = \sqrt{2gH}$$

So

$$C_v = \frac{\sqrt{\frac{gx^2}{2y \times 2gH}}}{\sqrt{\frac{x^2}{4yH}}}$$

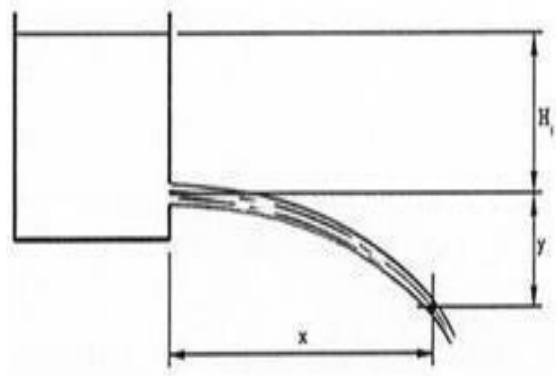

Since actual area of the jet is less than the area of the orifice, and the actual velocity is less than the theoretical velocity; therefore, actual discharge is less than the theoretical discharge. The ratio between the actual discharge and the theoretical discharge is called coefficient of discharge  $C_d$ .

$$C_d = \frac{Q_{act}}{a\sqrt{2gH}}$$

where  $\sqrt{2gH}$  is the theoretical discharge

The actual discharge passing through an orifice is given by

= Actual velocity at vena contracta  $\times$  Area of jet at vena contracta

$$= C_v\sqrt{2gH} \times C_c \times a$$

But  $\sqrt{2gH}$  is the theoretical discharge

$$\text{So, } \frac{\text{Actual discharge through Orifice}}{\text{Theoretical discharge through Orifice}} = \frac{C_v\sqrt{2gH} \times C_c \times a}{a\sqrt{2gH}} = C_c \times C_v$$

Or

$$C_d = C_c \times C_v$$

Or

$$C = \frac{C_d}{C_v}$$

Where  $\frac{Q_{act}}{Q_{theo}}$

The value of  $C_d$  of a standard orifice varies from 0.61 to 0.67

$$\text{Actual discharge, } Q_{act} = \frac{A \times r}{t} \text{ m}^3/\text{s}$$

Where  $A$  = area of measuring tank ( $\text{m}^2$ )

$R$  = rise in water level in the measuring tank in m

$t$  = time taken for the rise in water level

$$\text{Theoretical discharge, } Q_{theo} = a\sqrt{2gH} \text{ m}^3/\text{sec}$$

$a$  = area of the orifice in  $m^2$

$g$  = acceleration due to gravity  $m/s^2$

$H$  = head over the orifice in  $m$

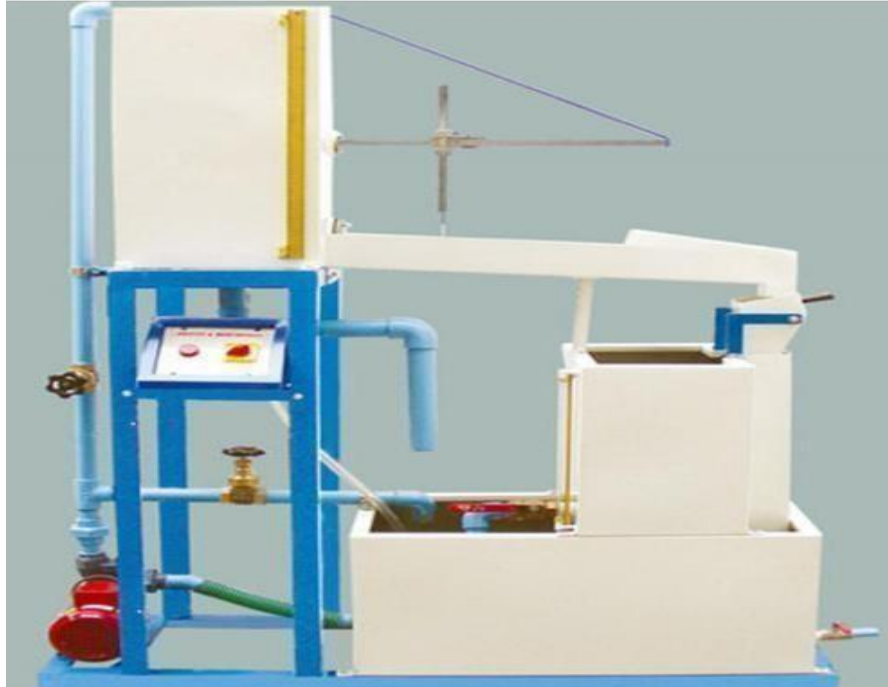

## PROCEDURE: -

1. Adjust the inflow of water to the inlet tank till the steady state condition is achieved by in and outflow from the orifice and the head causing flow through the orifice as indicated by the Piezometer tube is constant. Measure the head ' $H$ '.
2. Using the hook gauge, measure  $x$  and  $y$  coordinates at different points on the centre line of the jet. Knowing ' $H$ ', the head causing flow and  $x$  and  $y$  co-ordinates, coefficient of velocity can be obtained from the formula,

$$C_v = \frac{x^2}{4yH}$$

3. Note the initial reading of water level in the measuring tank, and simultaneously start the stop watch. After an interval of time note the reading of the water level. Difference in the two readings gives the rise in water level during the given time. Knowing, area of

measuring tank, actual discharge  $Q_a$  can be obtained. Hence  $C_d$  can be calculated as

$$C_d = \frac{Q_{act}}{a\sqrt{2gH}}$$

4. Calculate  $C_c = \frac{C_d}{C_v}$

5. Repeat the above steps for different heads  $h$  and take five readings.

6. Repeat the experiment for mouth piece and convergent orifice.

### OBSERVATION: -

Dia of circular orifice = 10mm = 1 cm

Area of circular orifice ( $a$ ) =  $\frac{\pi d^2}{4} \text{ cm}^2 = 0.78 \text{ cm}^2$

Dia of circular mouth piece = 10mm = 1 cm

Area of circular mouth piece ( $a$ ) =  $\frac{\pi d^2}{4} \text{ cm}^2 = 0.78 \text{ cm}^2$

Sump Tank Capacity = 50 Liter

Collecting tank Capacity = 30 Liter

Area of collecting tank ( $A$ ) = 25\*30 = 750  $\text{cm}^2$

### OBSERVATION AND TABULATION:

Sl. No.	Head ( $H$ )	Time ( $t$ )	$x$	$y$	$Q_{act}$	$Q_{theo}$	$C_d$	$C_v$	$C_c$
1									
2									
3									
4									
5									

Area of the measuring tank ( $A$ ) =  $L \times B$

$L$  = length of measuring tank



$B$  = breadth of measuring tank

Actual discharge,  $Q_{act} = \frac{A \times r}{t} \text{ m}^3/\text{s}$

Theoretical discharge,  $Q_{theo} = a\sqrt{2gH} \text{ m}^3/\text{sec}$

Coefficient of discharge,  $C_d = \frac{Q_{act}}{Q_{theo}}$

Coefficient of velocity,  $C_c = \frac{x}{\sqrt{4yH}}$

Coefficient of contraction,  $C_c = \frac{C_d}{C_v}$

### **CONCLUSION: -**

From the above experiment, the value of  $C_d$ ,  $C_c$  and  $C_v$  of orificemeter was found to be \_\_\_\_\_, \_\_\_\_\_ & \_\_\_\_\_ respectively.

### **POST LAB QUESTION: -**

1. Define orifice.
2. Define venacontracta.
3. Define coefficient of contraction.
4. Define relation between  $C_d$ ,  $C_c$  and  $C_v$ .

# EXPERIMENT – 10

## AIM OF THE EXPERIMENT: -

Determination of darcy's coefficient from flow through pipe.

## APPARATUS REQUIRED: -

SL. NO.	EQUIPMENT	SPECIFICATION	QUANTITY
01	Differential manometer		01
02	Pressure tapping cocks		01
03	Stop watch		01
04	Collecting tank fitted with piezometer tube		01
05	Different diameter pipes		

## THEORY: -

When a fluid flows through a pipe, certain resistance is offered to the flowing fluid, which results causing loss of energy. Froude conducted a series of experiments to investigate frictional resistance offered to the flowing water by different surfaces. From the results of his experiments, Froude derived the following conclusions:

1. The frictional resistance varies approximately with the square of the velocity.
2. The frictional resistance varies with the nature of the surface.

According to Darcy's equation,

$$h_f = \frac{4flv^2}{2gd}$$

where  $h_f$  = head loss due to friction in m in water =  $x \left( \frac{S_m}{S_w} - 1 \right)$

$x$  = Manometer deflection =  $x_2 - x_1$  in m of Hg

$S_m$  = Specific gravity of Hg

$S_w$  = Specific gravity of water

$l$  = length of pipe between pressure tappings in m

$v$  = velocity of flow =  $Q/a$

$Q$  = actual discharge

$a$  = area of pipe in  $m^2$

$$a = \frac{\pi d^2}{4} m^2$$

$d$  = diameter of the pipe in m

$$Q = \frac{A \times R}{t} \text{ m}^3/\text{s}$$

$A$  = area of measuring tank in  $\text{m}^2$

$R$  = Rise in water level in the collecting tank in m

$t$  = Time taken for the rise in sec

$f$  = Co-efficient of friction (Darcy's constant)

$$f = \frac{2gdh_f}{4lv^2}$$

## PROCEDURE: -

1. Note the pipe diameter ( $d$ ), length of the pipe( $l$ )
2. Make sure only required water regulator valves and required valves at tappings connected to manometer are opened.
3. Start the pump and adjust the control valve just enough to make fully developed flow but laminar flow. Wait for sometimes so that flow is stabilized.
4. Measure the manometer deflection  $x$  across the pressure tappings.
5. Close the outlet valve of the collecting tank and record the time  $t$  taken for rise in water level  $R$  in the collecting tank by using a stop watch.
6. Change the pressure tappings to the pipes of different diameters and repeat the steps from 1 to 5.
7. Calculate the Darcy's Constant for Pipe no 1, 2 & 3.

## OBSERVATION AND TABULATION: -

### A. FOR PIPE NO.1:

Diameter of the pipe ( $d$ ) =

Length of the pipe ( $l$ ) =

Length of the collecting tank ( $L$ ) =

Breadth of the collecting tank ( $B$ ) =

Rise in water level in the measuring tank ( $R$ ) =

Sl. No.	Time (sec)	Manometer readings			$h_f$ (m)	$Q$ ( $m^3/s$ )	Velocity ( $v$ ) (m/s)	Coefficient of friction ( $f$ )
		$X_1$	$X_2$	$x$				
1								
2								
3								
4								
5								
6								

**B. FOR PIPE NO.2:**

Diameter of the pipe ( $d$ ) =

Length of the pipe ( $l$ ) =

Length of the collecting tank ( $L$ ) =

Breadth of the collecting tank ( $B$ ) =

Rise in water level in the measuring tank ( $R$ ) =

Sl. No.	Time (sec)	Manometer readings			$h_f$ (m)	$Q$ ( $m^3/s$ )	Velocity ( $v$ ) (m/s)	Coefficient of friction ( $f$ )
		$X_1$	$X_2$	$x$				
1								
2								
3								
4								
5								
6								

**C. FOR PIPE NO.3:**

Diameter of the pipe ( $d$ ) =

Length of the pipe ( $l$ ) =

Length of the collecting tank ( $L$ ) =

Breadth of the collecting tank ( $B$ ) =

Rise in water level in the measuring tank ( $R$ ) =

Sl. No.	Time (sec)	Manometer readings			$h_f$ (m)	$Q$ ( $m^3/s$ )	Velocity (v) (m/s)	Coefficient of friction (f)
		$X_1$	$X_2$	$x$				
1								
2								
3								
4								
5								
6								

### CONCLUSION: -

From the above experiment, the value of Darcy's coefficient from flow through pipe was found out to be .

### POST LAB QUESTION: -

1. Define Darcy's coefficient.
2. What are the different types of energy losses in flow through pipe?
3. Define Darcy's formula

