



Email ID: gpblsmechanicalengg@gmail.com

DEPARTMENT OF MECHANICAL ENGINEERING
GOVT. POLYTECHNIC, BALASORE

LAB MANUAL
MECHANICAL ENGINEERING -I (Pr.2)
3RD SEMESTER



GOVT. POLYTECHNIC, BALASORE

GENERAL LABORATORY INSTRUCTIONS

- You should be punctual for your laboratory session and should not leave the lab without the permission of the teacher.
- Each student is expected to have his/her own lab book where they will take notes on the experiments as they are completed.
- The lab books will be checked at the end of each lab session. Lab notes are a primary source from which you will write your lab reports.
- You and your batch mates will work closely on the experiments together. One partner doing all the work will not be tolerated. All the Batch mates should be able to explain the purpose of the experiment and the underlying concepts.
- Please report immediately to the member of staff or lab assistant present in the laboratory; if any equipment is faulty.

ORGANIZATION OF THE LABORATORY

- It is important that the experiments are done according to the timetable and completed within the scheduled time.
- You should complete the pre lab work in advance and utilize the Laboratory time for verification only.
- The aim of these exercises is to develop your ability to understand, analyze and test them in the laboratory.
- A member of staff and a Lab assistant will be available during Scheduled laboratory sessions to provide assistance.
- Always attempt experiments; first without seeking help.
- When you get into difficulty; ask for assistance.

ASSESSMENT

- The laboratory work of a student will be evaluated continuously during the semester for 25 marks. Of the 25 marks, 15 marks will be awarded for day-to-day work.
- For each experiment marks are awarded under three heads:
 - Pre lab preparation - 5 marks
 - Practical work - 5marks, and
 - Record of the Experiment - 5marks
- Internal lab test(s) conducted during the semester carries 10 marks.
- End semester lab examination, conducted as per the JNTU regulations, carries 50 marks.
- At the end of each laboratory session you must obtain the signature of the teacher along with the marks for the session out of 10 on the lab notebook.

LAB REPORTS

- Note that, although students are encouraged to collaborate during lab, each must individually prepare a report and submit.
- They must be organized, neat and legible.
- Your report should be complete, thorough, understandable and literate.
- You should include a well-drawn and schematic for each experiments Investigated.
- Your reports should follow the prescribed format, to give your report structure and to make sure that you address all of the important points.
- Graphics requiring- drawn straight lines should be done with a straight edge. Well drawn freehand sketches are permissible for schematics.
- Space must be provided in the flow of your discussion for any tables or figures. Do not collect figures and drawings in a single appendix at the end of the report.
- Reports should be submitted within one week after completing a scheduled lab session.

PRESENTATION

- Experimental facts should always be given in the past tense.
- Discussions or remarks about the presentation of data should mainly be in the present tense.
- Discussion of results can be in both the present and past tenses, shifting back and forth from experimental facts to the presentation.
- Any specific conclusions or deductions should be expressed in the past tense.

REPORT FORMAT

Lab write ups should consist of the following sections:

- **Aim:** A concise statement describing the experiment and the results. This is usually not more than 3 sentences. Since the abstract is a summary of what you have done, it's a good idea to write this last.
- **Apparatus:** Describe what equipment and components you used to conduct the experiment.
- **Theory:** Several paragraphs that explain the motivation of the experiment. Usually in this statement you state what you intent to accomplish as well as the expected results of the experiment.
- **Procedure:** Describe how you conducted the experiment.
- **Results and Analysis:** This is the main body of the report. Graphs, tables, schematics, diagrams should all be included and explained. Results of any calculations should be explained and shown. State the results of the experiment. Include any problems encountered.
- **Conclusion:** Explain how the experiment went, and whether you were able to achieve the expected results stated in the introduction.

General Rules:

1. Lab Access: Only authorized personnel should have access to the lab.
2. Attire: Wear appropriate lab attire, including safety goggles, closed-toe shoes, and lab coats.
3. No Food or Drinks: Eating, drinking, and chewing gum should be prohibited inside the lab area.
4. Equipment Use: Use equipment only if you are trained and authorized to do so.
5. Follow Procedures: Adhere strictly to the established lab procedures and protocols.
6. Safety Equipment: Know the locations of safety showers, eyewash stations, fire extinguishers, and first aid kits.
7. Report Incidents: Immediately report accidents, spills, or any equipment malfunction to the lab supervisor.

Mechanical Lab Precautions:

1. Tool Safety: Handle tools and equipment with care. Return them to their designated places after use.
2. Machine Safety: Follow proper procedures while operating machinery to prevent accidents.
3. Protective Gear: Wear appropriate personal protective equipment (PPE) such as gloves, helmets, or masks based on the task being performed.
4. Ventilation: Ensure adequate ventilation in the lab, especially when working with materials that produce fumes or gases.
5. Chemical Handling: Handle chemicals cautiously, following recommended storage, usage, and disposal guidelines.
6. Electrical Safety: Be aware of electrical hazards and use insulation, grounding, and proper wiring when working with electrical components.

Additional Safety Measures:

1. Emergency Procedures: Understand evacuation plans and emergency procedures in case of fire, chemical spills, or other emergencies.
2. Labeling: Clearly label all containers with the contents, date, and any hazards they pose.
3. Workspace Cleanliness: Keep workspaces tidy to minimize potential hazards and allow for clear movement.
4. No Unauthorized Experiments: Avoid conducting experiments without proper approval or supervision.

Protocols for Specific Experiments:

1. Risk Assessment: Conduct a thorough risk assessment before starting any experiment and implement necessary safety measures.
2. Supervision: Ensure experiments are supervised by experienced personnel, especially when dealing with high-risk procedures or equipment.

EXPERIMENT NO.1

Aim of the experiment: Determination of end reactions in a simple supported beam using parallel force apparatus.

The oretical back ground:

If a system of coplanar forces acting on a rigid body, keep it in equilibrium then the algebraic sum of their moments about any point in their plane is zero.

Consider a beam simply supported at the ends and carrying many concentrated loads
Taking moments about R_b , we get

$$R_a \times l = W_1(l - a) + W_2(l - b) + W_3(l - c)$$

$$R_a = W_1\left(1 - \frac{a}{l}\right) + W_2\left(1 - \frac{b}{l}\right) + W_3\left(1 - \frac{c}{l}\right)$$

$$R_a = (W_1 + W_2 + W_3) - \frac{1}{l}(W_1a + W_2b + W_3c) \dots\dots\dots(1)$$

$$R_b = (W_1 + W_2 + W_3) - R_a \dots\dots\dots(2)$$

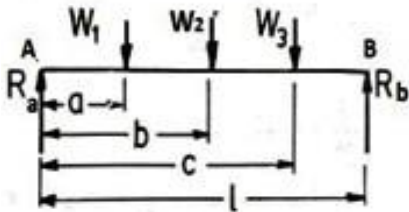

Experimental set up:

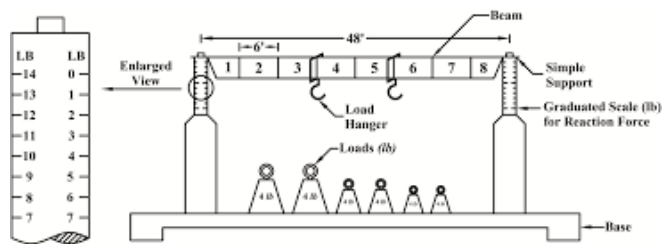

Resources required:

Sl.no	Name of the apparatus	Specification
1	Parallel force apparatus	Consisting of two digital weighing machine , steel bars with grooves for hanging weight. Complete with wooden scale, hooks and weights.
2	weights	100/500gms steel weights
3	Hangers	2 Nos

Procedure:

1. Measure the distance L
2. Note the zero error in the compression balances.
3. Place the beam on digital weighing balances and reset the weighing scale reading to zero.
4. Suspend different loads W_1, W_2 & W_3 at a distance a , b & c
5. Note the reaction on the beam given by the readings of compression balances (r_a & r_b)
6. Calculate R_a & R_b values from equation(1) and (2).
7. Repeat the experiment by taking different positions of W_1, W_2 & W_3 .
8. Find out %error between calculated and observed reading.

Precautions:

1. Zero error of the compression balance must be taken into account.
2. Weights should not be put on the beam with a jerk.
3. Slightly press the beam to remove any frictional resistance at the supports before taking the readings.
4. All the distances a , b , can should be measured accurately.
5. Reading so spring balances at A & B should be taken accurately.

Observations:

SL NO	Weights on be a man their distance from point A						Final reading at A & B		Reactions from calculations		%Error in R_a & R_b	
	W_1	W_2	W_3	a	b	c	r_a	r_b	$R_{calculated}$	$R_{bcalculated}$	%Error R_a	%Error R_b
1												
2												
3												

Results: The end reactions for simple supported beam (actual) is found to be

The end reactions for simple supported beam (actual) is found to be.....

Conclusions and recommendations if any:

Practical related questions:

1. What does as imply supported beam do?
2. What is SFD and BMD?
3. How do you take a moment of a beam?
4. What is effective length of a beam?
5. In simply supported beam deflection is maximum _____

EXPERIMENT NO .2

Aim of the experiment : Determination of Young's Modulus using Searl's Apparatus.

The or etical back ground:

Stress:-

It is defined as the ratio between the load and cross-sectional area of the given specimen .It may be defined as force per unit area.

Mathematically, Stress=load/area,

$$\sigma = (P/A)$$

Unit of stress is N/M^2 or KN / M

Strain: It is define as the ratio between the change in the length to its original length of the given specimen.

Mathematically,

$$\text{Strain} = \text{change in length /original length } e =$$

$$\Delta l/l, \text{ It has no unit.}$$

Young's modulus:-

It is the ratio between stress and strain. Sometimes referred to as the modulus of elasticity. It is a mechanical property that measures the stiffness of a solid material. It quantifies the relationship between tensile stress and axial strain in the linear elastic region of a material.

Mathematically,

$$\text{Young's modulus} = \text{stress/strain} = E = \sigma/e \text{ Its unit is}$$

KN/M^2 or N/M^2 .

Experimental set up:

Technical Specification:

Diameter of copper wire(d)= m²

Cross-sectional area of the specimen(A)=(π /4)x D²=..... M²

Original Length of copper wire (L)= m

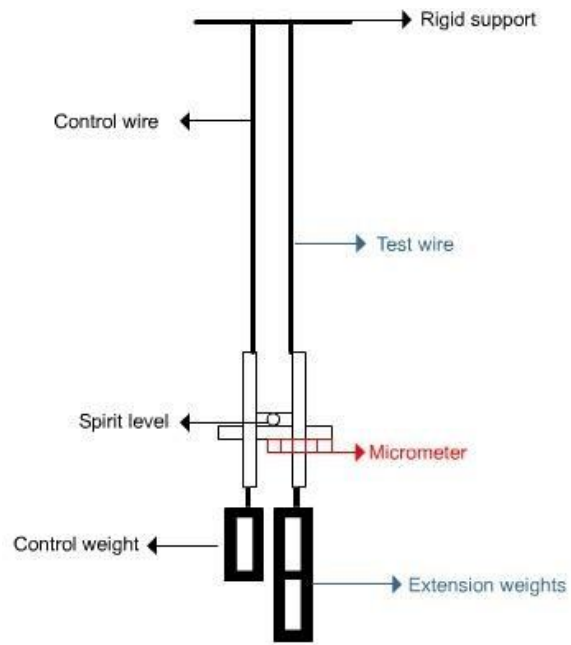

SEARL'S APPARATUS

Resources required:

SLNO.	NAME OF THE APPARATUS	SPECIFICATION
01	Searl's apparatus	
02	Vernier caliper	L.C=0.02mm
03	Steel rule	L . c =0.5mm
04	Copper wire	D =0.001mm
05	Balancing weight	1Kg
06	Weight pan	
07	Plier	

Procedure:-

1. Take two copper wire so frequent site length.
2. Hang the searl's apparatus by the two copper wires of which one wire is fixed wire and another is testing wire.
3. Now measure the diameter and length of the wire.
4. Then set the weight pan in the testing side.
5. Then give some load in the load pan .The wire will elon gate.
6. Now writed own the load applied and the change in length in the observation AW table.
7. Then gradually increase the loads and take at least five readings.

Precautions if any:

1. Weight (load) should be applied gradually.
2. Always maintain the spirit level horizontal with the base
3. Avoid errors during measurement of length ,diameters ,etc.
4. Over loading should be avoided.

Observation table and calculation:

SL.NO	Load applied(P)kg	Stress(ρ) (P/A)	Change in length(ΔL)m	Strain(ϵ) ($\Delta L/L$)	Yooung's modulus(σ/ϵ)
1					
2					
3					
4					
5					

Result: young's modulus of the given specimen is found to be.....

Practical related questions:

1. Explain stress and its unit.
2. Define young's modulus and state its sign if icance.
3. Why we use two wire sinsearle 's apparatus?
4. Is It necessary that both wires Should be of same material and same length?
5. How temperature affects young's modulus?
6. Which is more elastic a rubber or steel?

EXPERIMENT NO .3

Aim of the experiment: Determination of torsional rigidity of the shaft using torsion testing machine

Theoretical back ground:

Materials commonly used in the manufacturing industry ,such as metal fastener sand beams are often subjected to torsion; hence determination of their strength under twisting is necessary. Without torsion test, materials would not be properly vetted before being launched for commercial use. In torsion test the measurable values include the modulus rigidity, yield shear strength, ultimate shear strength and modulus of rupture in shear.

The value of modulus of rigidity can be found out through observations, made during the experiment and by using the torsion equation.

The torsion equation is:- $T/J=G.\theta/L$.

$$\text{So, } G = T.L / J.\theta$$

Where,

T=Torque applied.

$$J=\text{Polar moment of inertia}=\pi Xd^4 \frac{_}{32}$$

d=Diameter of specimen.

C=Modulus of rigidity.

□=Angle of twist.

L=Gauge length of the specimen in m.

Diagram/setup:

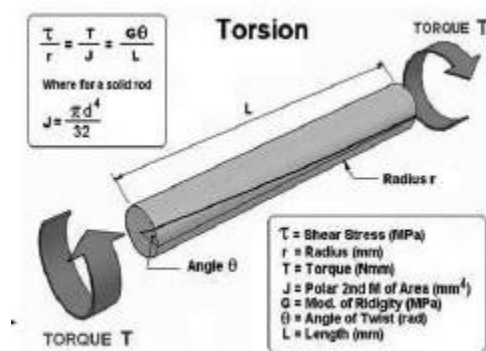

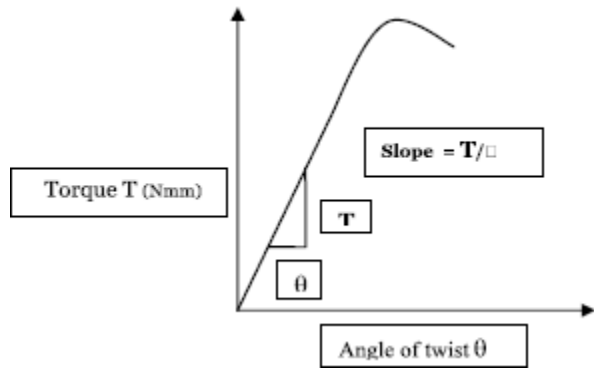

Torsion testing machine

Recourses required:

Sl .no	Name of the apparatus	Broad specification
01	Torsion testing machine	Make: En kay .Max. torque capacity: 200.Torque range: 200,100,50. No of divisions on dial: 500.Clearance between grips: 0-420mm. Grips for round specimen: 7-10,10-15,15-20mm. Grips for flat specimen width: 3- 10,30mm. Motor: 440v/3 phase/50HZ/0.5HP. Fixed with auto torque selector to regulate torque ranges, contains geared motor to apply torque to specimen. Torsion and twist test on various metal rods and flats, torque measurement by pendulum dynamometer system. One of the grips shall be capable of being rotated around the axis of the test piece while the others hal no be subjected to any angular deflection .The distance Between the grips shall be capable of adjustment for different lengths.
02	Mild steel specimen	D=..... L=.....
03	Steel rule	Least count=0.5mm
04	Vernier caliper	Least count=0.02mm

PROCEDURE:-

1. Select the driving dogs to suit the size of the specimen and clamp it in the machine by adjusting the length of the specimen by means of a sliding spindle.
2. Measure the diameter of the specimen at about three places and take the average values.
3. Choose the appropriate range by capacity change lever.
4. Set the maximum load pointer to zero.
5. Set the protractor to zero for convenience.
6. Carry out straining by rotating one of the ends with hand wheel or electric motor in either direction.
7. Record there adding soft or que and angle of twist (T&□).
8. Continue to test the sample for the destruction with increasing values of strain . Record the values of T&□ up to fracture.
9. Plota torque verses angle of twist graph.
10. Read of coordinates of a convenient point from the straight line portion of the graph and calculate the value of the modulus of rigidity by using torsion equation.

Precautions to be followed:

1. Avoid over acceleration of machine and maintain proper rate of loading.
2. Place the sample exactly at there quired location only and fix properly.
3. Keeps distance from the machine during operation
4. The grips having requisite hardness and straight faces must be used.
5. The grips should not apply any bending or to the test specimen.

Observations and calculations:

Material of the sample:-.....

Diameter of the sample,

$d_1 = \dots\dots\dots \text{mm}$, $d_2 = \dots\dots\dots \text{mm}$, $d_3 = \dots\dots\dots \text{mm}$

Average dia =.....mm

Gauge length of the sample=..... mm

Observations during experiments:

Sl. no	Torque(T) in N-mm	Angle of twist(θ)	
		θ in degrees	θ in radians

Sample calculations:

Polar moment of inertia(J)= $\frac{\pi \times d^4}{32}$ mm⁴

Plot T v θ graph from above reading and find out the slope of the graph (in elastic region) From torsion equation, we know that $G = T.L/J.\theta$

$G = (\text{slope of the graph } T \text{ v } \theta) \times (L/J) = \dots\dots\dots \text{ N/mm}^2$

Result: modulus of rigidity of given sample specimen is found to be.....

Practical related questions:

1. Calculate modulus of rigidity of the same sample material for 100mm dia and 1m length.
2. Define torque and state the relation between torque and angle of twist.
3. What is the purpose of torsion test?
4. Why do we choose mild steel as our specimen material?
5. Which section (round ,square ,rectangular and open)is best in torsion?

EXPERIMENT NO .4

Aim of the experiment: Determination of Salient points (Young's Modulus, Yield Point, Fracture point) from stress –strain curve using Universal Testing Machine (UTM).

Theoretical back ground:

The tensile test is most applied one, of all mechanical tests. In this test ends of test piece are fixed into grips connected to a straining device and to a load measuring device. If the applied load is small enough, the deformation of any solid body is entirely elastic. An elastically deformed solid will return to its original form as soon as load is removed. However, if the load is too large, the material can be deformed permanently. The initial part of the tension curve (stress- strain curve) which is recoverable immediately after unloading is termed as elastic zone and the rest of the curve which represents the manner in which solid undergoes plastic deformation is termed plastic zone. The stress below which the deformations essentially entirely elastic is known as the yield strength of material. In some material the onset of plastic deformation is denoted by a sudden drop in load indicating both an upper and a lower yield point. However, some materials do not exhibit a sharp yield point. During plastic deformation, at larger extensions strain hardening cannot compensate for the decrease in section and thus the load passes through a maximum and then begins to decrease. This stage the “ultimate strength” which is defined as the ratio of the load on the specimen to original cross-sectional area, reaches a maximum value. Further loading will eventually cause ‘neck’ formation and rupture.

Stress: when a material is subjected to external loading, then the internal resistance per unit cross section, set up in the material to deformation is called as stress.

Ultimate tensile strength of a material is maximum load carrying capacity of the material per unit cross sectional area in tension.

Tensile strain: change in length /original length.

Hooke's law: within elastic limit, stress is directly proportional to strain.

Modulus of elasticity: the ratio of stress to strain within elastic limit.

Percentage of elongation: the percentage change in gauge length with reference to the original gauge length.

UTM machine is designed for testing metals and other materials under tension, compression, bending, transverse and shear loads. The Straining/Loading Unit consists of a hydraulic cylinder, an electrical geared motor coupled to a chain sprocket drive and a table coupled with the ram of the hydraulic cylinder mounted on a robust and rigid cast iron base. The cylinder and the ram are individually lapped to eliminate friction. The upper cross-head is rigidly fixed to the table by straight, hard chrome plated steel columns. The lower cross head is connected to two precision threaded (screwed) columns which are driven by an A.C. Induction motor.

Block diagram/setup:

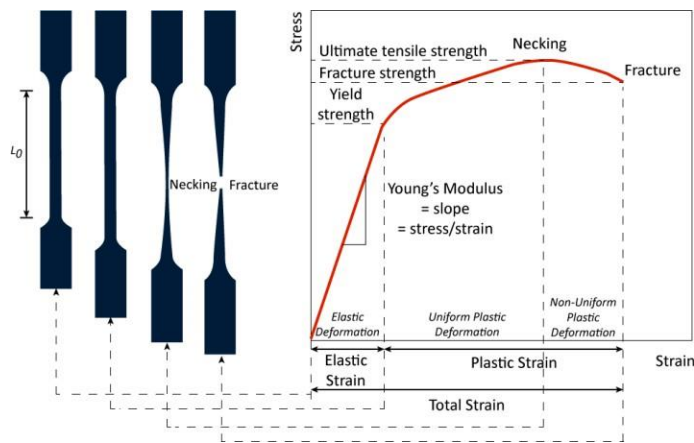
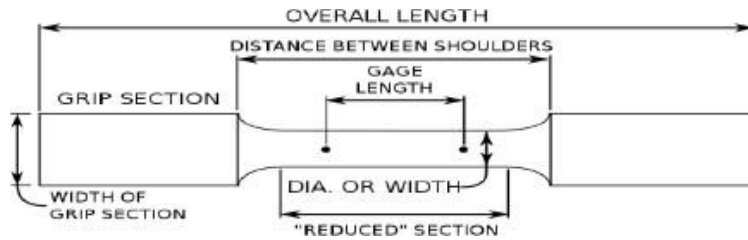

Resources required:

Sl. no	Apparatus	specification
1	Universal Testing Machine	Servo hydraulic fully computerized, capacity: 400kN. Motorized control valve, straining at variable speeds, motor driven threaded column, RS 232 serial port for PC control, measuring range: 0-400kN, load resolution: 20kN, clearance between columns: 500mm, 440 volt, 50Hz, 3 phase power supply. Hydraulic oil: 67,68 grade,
2	Vernier calliper	l.c= 0.02
3	Steel rule	l.c = 0.5
4	Mild steels pecimen	D=..... L=.....

Procedure:

1. Measure the original length and diameter of the specimen. The length may either be length of gauge section which is marked on the specimen with a preset punch or the total length of the specimen.
2. Ensure that the release valve and the control valve mounted on control unit are closed.
3. Put the electric switch on. Move the lower cross head up or down with the help of UP/DN press button on control unit to adjust the space with the length of the specimen.
4. Insert the specimen into grips of the machine and fix it tightly.
5. Put all the required data in software installed in PC for the given specimen and save it.
6. Begin the load application by pressing the start button on control unit and at the same time click on start button on PC. Slightly open the control valve.
7. Record the maximum load. Observe the decrease in load and neck formation on the specimen.
8. Record the load at fracture and observe the load vs displacement graph. Then switch off the machine.
9. Close the control valve and open the release valve.
10. Remove the specimen and observe the cup and cone formation at the fracture point.
11. Rejoin the two pieces and measure the final gauge length and reduced diameter.
12. Take notes for yield stress, ultimate stress and fracture point stress from the load vs displacement graph.
13. Calculate the slope of the graph which will give modulus of elasticity.

Precautions if any:

1. Avoid overloading and maintain proper rate of loading.
2. Place the sample exactly at the center of the grips of the cross heads.
3. Keep safe distance from machine during operation.
4. Open the release valve after the machine is switched off.
5. Keep distance from electric wires.

Observations:

- (a) Initial diameter of specimen =
- (b) Initial gauge length of specimen =
- (c) Load at yield point =
- (d) Ultimate load =

- (e) Breaking load=.....
- (f) Ultimate load after specimen breaking=.....
- (g) Final length after specimen breaks=.....
- (h) Diameter of specimen after breaking takes place=.....

Calculations:

1. Cross sectional area $=\frac{\pi d^2}{4}$ mm²
2. Cross sectional area after breaking of specimen=.....mm²
3. Yield stress=yield load/Cross sectional area= N/mm²
4. Ultimate stress=ultimate stress/Cross sectional area =... N/mm²
5. Breaking stress=breaking load/Cross sectional area=.....N/mm²
6. Actual breaking stress=breaking load/reduced Cross sectional area=... N/mm²
7. Stress(with in elastic limit)= N/mm²
8. Corresponding strain=.....
9. Young's modulus=stress/strain=..... N/mm²

Results:

1. Young's modulus=.....
2. Yield stress=.....
3. Fracture/breaking stress=.....

Practical related questions:

1. Draw and explain stress strain diagram for ductile as well as brittle materials.
2. What is factor of safety?
3. Write down the various types of test that can be conducted in your UTM.
4. Compare elastic modulus of rubber with that of plastic.

EXPERIMENTNO.5

Aim of the experiment: Determination of hardness number by Rockwell hardness testing machine.

Theoretical background:

Rock well hardness test differs from Brinell hardness test in that the hardness is determined from the depth of indentation made by the indenter under a constant load. Various types of indenters may be used in Rockwell hardness tests: diamond indenter and steel-ball indenters of diameter 1/16,1/8,1/4,or1/2inch. In this test, the indenter is pressed into the specimen surface under an initial minor (light) load followed by a major (heavy) load. The additional depth of indentation made by the indenter under the major load beyond that by the minor load is measured and converted to a hardness number.

The hardness number is inversely related to the depth of indentation. In regular Rockwell hardness tests, the minor load is always 10 kg while the major load can be 60,100,or150 kg. A letter is assigned to each scale that employs a particular combination of indenter and major load. A hardness number is suffixed by first the letter H (for hardness), then the letter R (for Rockwell), and finally the letter that indicates the scale used. For example, a value of 45 on the Rockwell C scale is expressed as 45 HRC.

Rockwell hardness tester gives the direct reading of hardness number on a dial provided with the machine. The specimen may be cylinder, cube, thick or thin metallic sheets.

Typeof specimen	Typeof Indentor	Scale	Total load(P) Kg-F
Hard Metals	Diamond cone	C(Black graduations)	150
Soft Metals	Ball(1/16")	B (Red graduations)	100

Block diagram/setup:



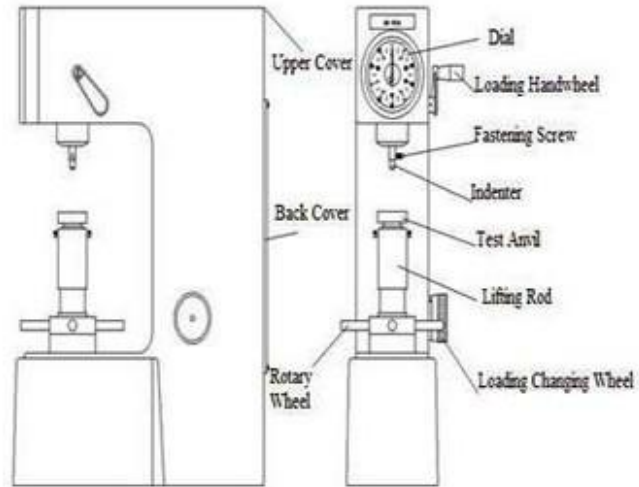

Resources required:

Sl.no	Apparatus	specification
1	Rock well hardness testing machine	
2	Indentor	
3	Weights	
4	Standard specimen	

Procedure:

1. Turn power switch located in lower rear panel "ON".
2. Select desired scale by means of the "TEST SCALE SCROLL". This key may be depressed for each scale advancement or held in for rapid scrolling.
3. Select and install the proper indenter, as indicated in the "PENETRATOR" display.

4. Select the proper major load, as indicated in the "MAJOR LOAD kg" display, by means of the weight selector dial.
5. Place the specimen on the anvil.
6. Raise specimen into contact with the indenter by turning capstan hand wheel clockwise slowly. The bar LEDs (red) will light up and the read display will show "MINORLD".
7. Continue to slowly turn the capstan hand wheel. Stop the hand wheel when the bar LEDs reach the "SET" zone. The major load will automatically be applied and then removed. The read display will show "TESTING" and then the numerical value and the scale tested.
8. Remove the minor load by turning the capstan hand wheel counter-clockwise. Continue to lower the specimen until it clears the indenter. The test is concluded.

Observations:

S.N	Material	Thickness	Scale	Type of Indenter	Minor Load	Major Load	Measured Hardness			Average Rockwell Hardness
					kgf	kgf	1	2	3	
1										
2										
3										

Results:

EXPERIMENTNO.5

BRINELL HARDNESS TEST

AIM: To determine the hardness of the given specimen using Brinell hardness test.

Theoretical Background: The method of hardness testing was introduced by J.A. Brinell in 1900. In this test, a standard hardened steel ball (dia D) is indented into the surface of the specimen by a gradually applied load (P) which is maintained on the specimen for definite time (usually 10 or 15 sec). Ball of 10 mm, 5 mm, and 2.5 mm are generally used. The diameter of the impression or indentation (d) is measured by microscope and the Brinell hardness number (B.H.N.) is found out by following formula.

$$\text{BHN} = \frac{\text{Load Applied (kgf)}}{\text{spherical surface area of indentation}}$$

$$\text{BHN} = \frac{2P}{\pi D(D - \sqrt{D^2 - d^2})}$$

Experimental setup:

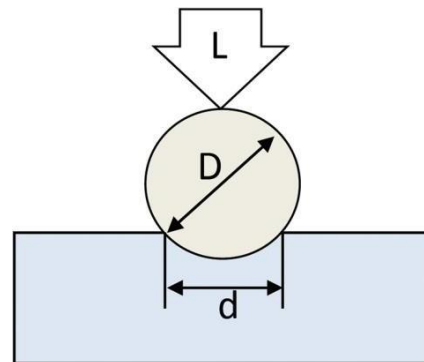

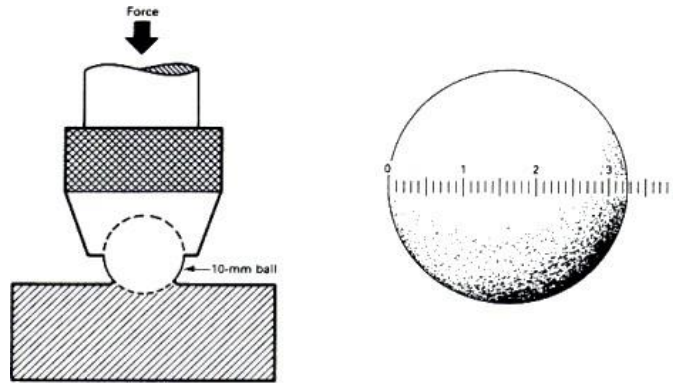

Resourcesrequired:

Sl.no	Apparatus	specification
1	Brinell hardness testing machine	Load range: 250kgf up to 3000kgf, max test height: 410mm, depth of throat:200mm, net weight: 500kg,height: 1185mm, size: 650 x 670 mm, drive: electric motor 0.33/0.5 HP, flanged mounted, 440v/50hz/3 phase power supply, max depth of spindle: 180mm, solid vibration free base.
2	Required accessories	Loading pan and loose weights (each equivalent to 250kgf), one testing table, spanner, screw driver, brinell microscope.
3	Indenter	5mm,10mmdiaballindentertype
4	Standard specimen	Mild steel,Al,Cu,etc

Procedure:

1. In sert ball of diameter 'D' in the ball holder of machine.
2. Make the specimen surface clean by oil,grease,dustetc.
3. Make contact between the specimen surface and ball using jack adjusting wheel.
4. Push the required button for loading.
5. Pull the load release level and wait for 15 seconds.
6. Remove the specimen from the support table and locate the Indentation.
7. View the indentati on through microscope and measure the diameter 'd' of the indentation using micrometer fixed on the microscope.
8. Repeat the procedure and take three readings.

Precautions:

1. Apply the load slowly and gradually on the sample.
2. Distance between old impression and location for new impression should be 3D (three times the ball diameter)
3. After applying the specified load wait for 15 sec then remove the load.
4. The thickness of the test piece must not be less than 8 times the depth of impression.
5. The surface on which the Brinell impression is to be made should be sufficiently smooth and clean.

Observations:

S.N.	Test specimen material	Dia. of indenter D mm	Applied load Kgf(F)	Diameter of indentation (d)mm			Average diameter (d)mm	Brinell Hardness Number
				1	2	3		
1								
2								
3								

Calculation:

$$\text{BHN} = \frac{\text{Load Applied (kgf)}}{\text{spherical surface area of indentation}}$$

$$\text{BHN} = \frac{2P}{\pi D(D - \sqrt{D^2 - d^2})}$$

Result: The brinell hardness number of the given sample is found to be.....

Practical related questions:

1. State the difference between Hardness & Hardenability?
2. Describe the surface conditions necessary for Brinell hardness testing.
3. List the different type so find enters used in hardness testing?
4. List the materials which cannot be tested by Brinell hardness tester
5. State the reason for using ball in dentor so different diameter for Brinell hardness testing

EXPERIMENTNO.6

Aim of the experiment: Determination of toughness by using impact testing machine (izod/charpy)

Theoretical background:

Several engineering materials have to withstand impact or suddenly applied loads while in service. These loads are applied suddenly. The stress induced in these components is many times more than the stress produced by same load applied gradually. Therefore, impact tests are performed to assess shock absorbing capacity. Impact test signifies toughness of material that is ability of material to absorb energy during impact. Toughness takes into account both the strength and ductility of the material.

Two types of notch impact tests are commonly used. 1. Charpy test 2. Izod test.

In Izod test, the specimen is placed as cantilever beam. The specimen has a V-shaped notch of 45°. The notch is located on the tension side of the specimen during impact loading.

In Charpy test, the specimen is placed horizontally simply supported beam. The specimen has a V-shaped notch of 45° at the centre of the length. The notch is located on the tension side of the specimen during impact loading.

Energy absorbed in joules = initial energy in joules – final energy in joules

	Charpy Impact Testing	Izod Impact Testing
Materials Tested	Metals	Plastics & Metals
Types of Notches	U-notch and V-notch	V-notch only
Position of the Specimen	Horizontally, notch facing away from the pendulum	Vertically, notch facing toward the pendulum
Striking Point	Middle of the sample	Upper Tip of the sample
Common Specimen Dimensions	55 x 10 x 10 mm	64 x 12.7 x 3.2 mm (plastic) or 127 x 11.43 mm round bar (metal)
Common Specifications	ASTM E23, ISO 148, or EN 10045-1	ASTM D256, ASTM E23, and ISO 180

Experimental set up:

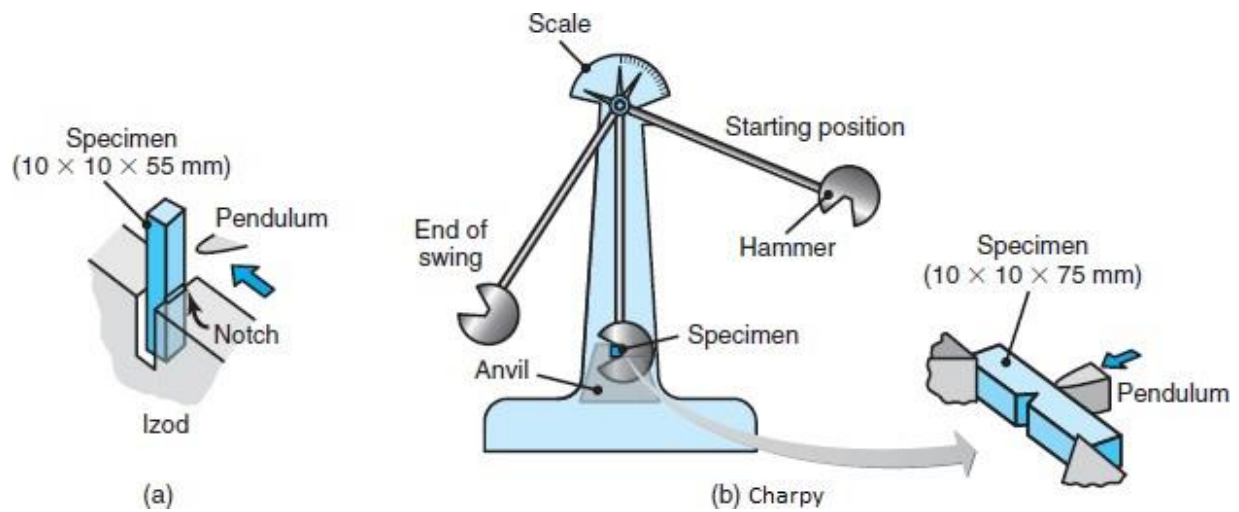
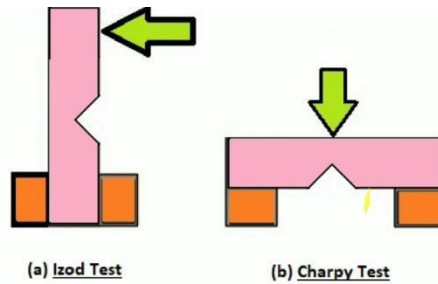

Resources required:

Sl .no	Name of the apparatus	Specification
01	Impact testing machine	Maxcapacity:300J/170J,minimumscalegraduation:0.5J,overallsize: 1.32m x 0.45m x 1.05m, net weight: 375kg, standard accessories, basic machine with hammer pipe, charpy and izod striker, protective railing, hand brake and stopper – 1set., digital display unit , caliper gauge for checking V notch, izod support for izod round specimen, self centering tong for quick and accurate setting of charpy test specimen.
02	Sample specimen	Mild steel, high carbon steel, dimensions given as in setup diagrams.
03	Vernier calliper	l.c=0.02
04	Tools and equipment used for specimen preparation and setting	Vice, hacksaw, files,gauges, players

Procedure:

1. For conducting charpy test,a proper striker is to be fitted firmly to the bottom of the hammer with the help of the clamping piece.
2. Bring the Hammer to its initial position of striking (140°) and strike without placing any specimen. Take the reading in digital indicator. This will give the initial energy reading. Keep in mind that there must be no person in the range of swinging hammer/ pendulum. Apply pedal brake after one swing to stop the oscillation.
3. Bring back the hammer to its initial striking position again and lock it.
4. The prepared specimen of required dimensions is then placed horizontally on vice with the V notch facing opposite to the striking face of the hammer.
5. Then release the hammer for striking the specimen. Take the final energy reading. The difference between initial and final reading will give the actual energy absorbed.
6. Similar procedures can be followed for izod test to measure the initial energy reading. Here hammer is released from 85° .
7. The specimen for izod test is then firmly fitted in the specimen support with the help of clamping screw and élan key. Care should be taken that the notch on the specimen should face to pendulum striker.

8. After ascertaining that there is no person in the range of swinging pendulum, release them pendulum to smash the specimen. Carefully operate the pendulum brake when returning after one swing to stop the oscillations.
9. Note down the final reading and determine the actual energy absorbed.

The notch impact strength depends largely on the shape of the specimen and the notch. the values determined with other specimens therefore may not be compared with each other.

Precautions:

1. Avoid improper handling of the equipments.
2. Prepare the specimen exactly as per dimensions.
3. While locking the hammer pay extra care.
4. While releasing the hammer for impact make sure that there is no person standing around the machine.
5. Set the digital display for either izod or charpy while performing the respective testings.

Observations:

Sl. no	Energy absorbed by the Specimen (izod /charpy)
1	
2	
3	

Results:

Izod / charpy impact value for specimen no.1=.....

Izod /charpy impact value for specimen no.2=.....

Izod /charpy impact value for specimen no.3=.....

Practical related questions:

1. List any two machine components that are subjected to impact loads.
2. What do you mean by toughness?
3. What do you mean by resilience and how it is different from toughness?
4. What is the necessity of making notches in the specimen?
5. Why it is necessary to perform impact test on a material?

EXPERIMENTNO.7

Aim of the experiment: Determination of flash point and fire point

Theoretical background:

Flash Point:-

The flash point of any fuel is the lowest temperature at which it can vaporize to form an ignitable mixture in air. At flash point the vapor may easily burn if the source of ignition is removed. The flash is not to be confused with auto ignition temp. Which does not require an ignition source.

Fire Point:-

The fire point of a fuel is the temperature at which it will continue to burn for at least 5 sec. After ignition by an open flame, fire point can be assumed to be about 10° C higher than the flash point.

The flash and fire points of a liquid fuel specimen are the indicators of its flammability. In general, flash point is the lowest temperature of the test specimen, corrected to a barometric pressure of 101.3kPa, at which the application of an ignition source causes the vapor of the test specimen to ignite momentarily and the flame to propagate across the surface of the liquid under the specified conditions of test. It is important to realize that the value of the flash point is not a physical constant but is the result of a flash point test and is dependent on the apparatus and procedure used. Fire point may be considered as the lowest temperature of the liquid at which vapor combustion and burning commences. A fire point happens when an ignition source is applied and the heat produced is self-sustaining, as it supplies enough vapors to combine with air and burn even after the removal of the ignition source.

Flash and fire point in engine perspective Gasoline has a flash point around -43° C whereas diesel has flash points higher than 52° C. Lower flash points are the indicators of good flammability and volatility. Therefore, gasoline makes faster vapour formation than diesel and instantly catches fire when spark, an external flame source, is provided. However, as its auto ignition temperature is high (in low compression ratio gasoline engine perspective), which is in the order of 247-280° C, it does not ignite prematurely due to the residual heat generated during compression stroke and heat transfer from wall. On the contrary, the higher flash point of diesel indicates poor vaporization tendencies and lesser tendency to ignite subjected to external flame source. However, as the auto ignition temperature of diesel is low (in high compression ratio diesel engine perspective), which is in the order of 210°C, diesel auto ignites easily with the residual heating during compression stroke and heat transfer from wall without the need of an external flame source such as spark plug. Poor vaporization tendency of diesel is dealt with in-cylinder swirl and high pressure injection. Vegetable oils have significantly high flash points which are in the order of diesel fuels and higher. Hence their vaporization and mixing are a huge challenge for direct engine applications. Therefore, vegetable oils are transesterified to produce fatty acid methyl esters or bio diesel which has comparable flash point for direct compression

ignited diesel engine application. In the alcohol category, methanol has a flash point of around 12° C and auto ignition temperature of 470° C. Similarly, ethanol has 16° C flash point and auto ignition temperature around 365° C indicating their close proximity to gasoline fuel and potential alternative fuel application in spark ignited engines.

Apparatus and consumables required:

- a) A Pensky-Martens flash point apparatus.
- b) Thermometer of suitable range.
- c) Test samples.

Penskey-Marten's Flash Point apparatus

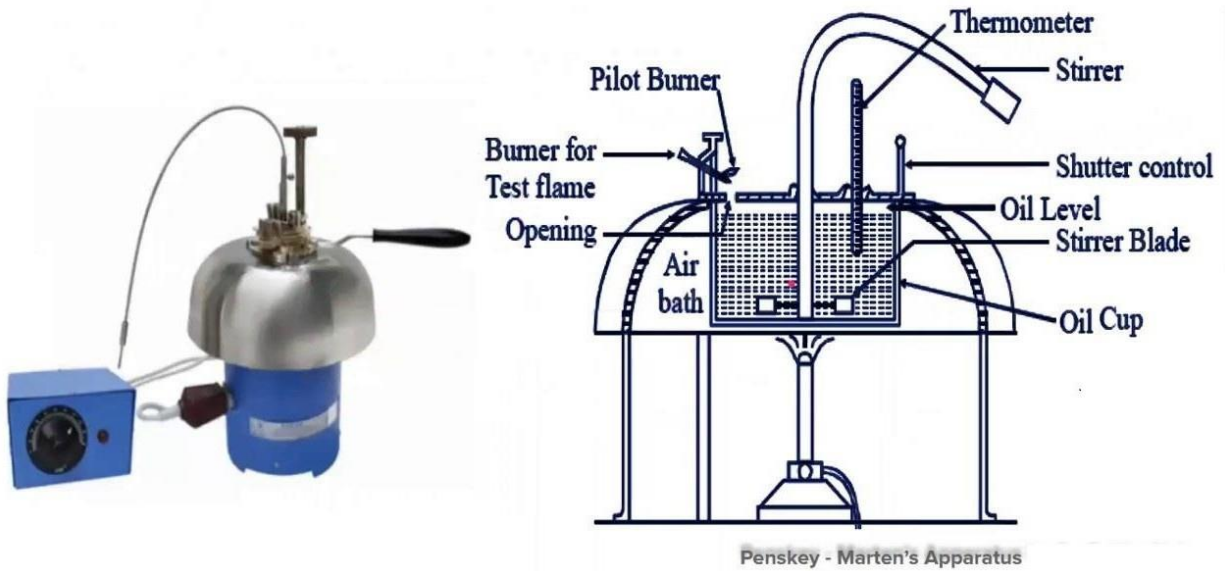

Preparation of samples:

- a) Samples should be in reasonably fluid state before testing. For asphalts and other viscous materials, preheating should be done to ensure fluidity before testing.
- b) Samples may be warmed with constant heating rate. However, under no circumstances, should be heated above a temperature that lies 16° C below the expected flash point.
- c) Samples containing dissolved water may be dehydrated with calcium chloride or by filtering through a suitable filter paper. If the same is not done, its consequence on experimental results and repeatability should be duly inferred.

Procedure:

1. Clean and dry all parts of the cup thoroughly.
2. Fill the cup with the sample to be tested to the level indicated by the filling mark.
3. Place the lid on the cup and set the latter on the stove.
4. Insert the thermometer and supply heat with the help of the thermostat switch to ensure temperature rise rate not more than 5 to 6° C per minute.
5. Turn the stirrer with 90 to 120 rpm in a down ward direction.
6. Provide the test flame time to time and start nearly 17° C below the expected flash point of the sample with 0.5 to 1° C gap.
7. Lower the test flame to the vapour space of the cup for 5s and allow it to be there for 1s. After that move the test flame up as quickly as possible and shutdown the lid for vapour build up.
8. Do not stir the sample while providing the test flame.
9. Denote the flash point and fire point accordingly.

Observations:

Types of fuel	Flash point	Fire point
Petrol		
Diesel		
Kerosene		

Results:

Practical related questions:

1. The lowest temperature at which the oils gives enough vapour is.....
2. The fire point is the lowest temperature at which the vapour of oil burns continuously for at least _____ when a small flame is brought near to it.
3. The fire point of an oil is about _____ higher than the flashpoint.
4. Pesky- Marten's apparatus is used to find out the _____
5. Oil cup in Pesky- marten's apparatus is made with _____

EXPERIMENT NO.8

Aim of the experiment: Joules Experiment.

1. Study of Joules experiment to validate first law of thermodynamics
2. The main aim of Joules Experiment was to determine the relationship between the work done and the quantity of heat produced in mechanical system.

The oretical background:

James P. Joule carried out his famous experiment; he placed known amounts of water, oil, and mercury in an insulated container and agitated the fluid with a rotating stirrer. The amounts of work done on the fluid by the stirrer were accurately measured, and the temperature changes of the fluid were carefully noted. He found for each fluid that a fixed amount of work was required per unit mass for every degree of temperature rise caused by the stirring, and that the original temperature of the fluid could be restored by the transfer of heat through simple contact with a cooler object. In this experiment you can conclude there is a relationship between heat and work or in other word heat is a form of energy.

Internal Energy

Through, Joule experiment what happen to energy between time it is added to water as work, and time it is extracted to heat? Logic suggests that this energy contained in the water in another form which called *internal energy*.

Internal energy refers to energy of molecules of substance which are ceaseless motion and possess kinetics energy. The addition of heat to a substance increases this molecular activity, and thus causes an increase in its internal energy. Work done on the substance can have the same effect, as was shown by Joule. Internal energy cannot be directly measured; there are no internal-energy meters. As a result, absolute values are unknown. However, this is not a disadvantage in thermodynamic analysis, because only changes in internal energy are required.

$$U = f(T, V)$$
$$\partial u = \left(\frac{\partial U}{\partial T} \right)_V \partial T + \left(\frac{\partial U}{\partial V} \right)_T \partial V$$
$$\int_{U_1}^{U_2} \partial U = \int_{T_1}^{T_2} \left(\frac{\partial U}{\partial T} \right)_V \partial T + \int_{V_1}^{V_2} \left(\frac{\partial U}{\partial V} \right)_T \partial V$$
$$\Delta U = \int_{T_1}^{T_2} C_v dT + \int_{V_1}^{V_2} \left(\frac{\partial U}{\partial V} \right)_T \partial V$$

In case of case ideal gas $\left(\frac{\partial U}{\partial V} \right)_T = 0$, and this lead to

$$\Delta U = \int_{T_1}^{T_2} C_v dT$$

Construction and Working:

The lay out of Joule's experiment is as shown in the figure.

1. Paddle wheel 2 was submerged in the heat-insulated vessel 1 to the walls of which vanes 3 were fastened, the vanes interfering with the motion of oil due to rotation of the paddle.
2. Rotation was imparted to the paddle (stirrer) by the falling load 4 of weight G , connected to the paddle by means of a rope and pulley 5.
3. As the weight falls through distance Δh , the work done by it (and, consequently, by the stirrer) is equal to the decrease in the potential energy of the weight $G\Delta h$.
4. The heat liberated in the oil-filled vessel is calculated from the rise in water temperature, measured with a thermometer.

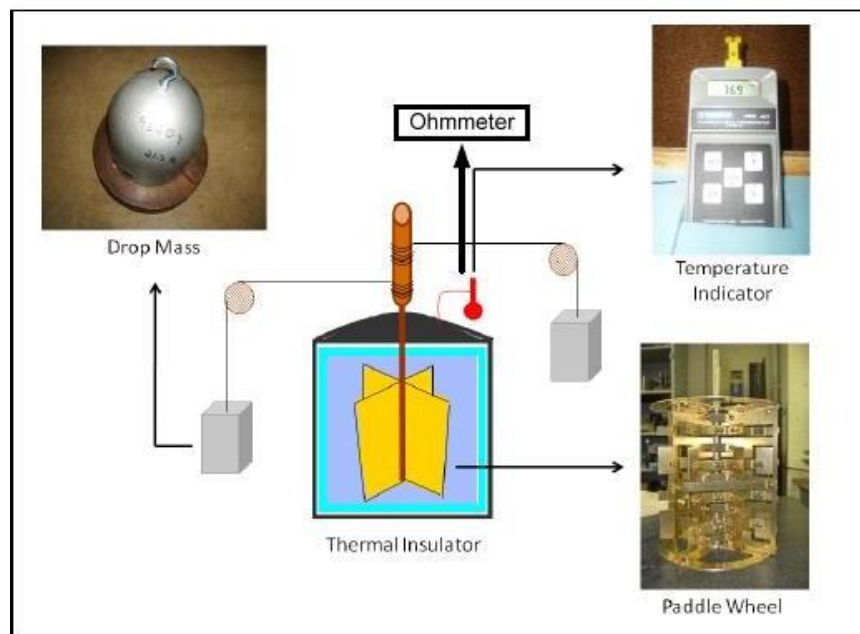
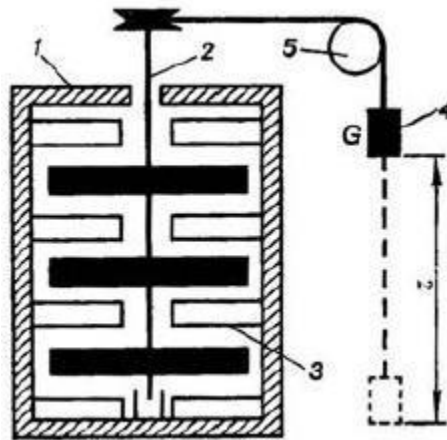

Observations:-

1. Weight $W=(G)=2\text{kg}$

2. Mass of Oil (m) = kg

3. Fall of weight through distance $z=$ feet(m)

4. Initial Temperature of oil $T_1=$ $^{\circ}\text{C}$

5. Final Temperature of oil $T_2=$ $^{\circ}\text{C}$

6. Specific heat of oil $C_p =$ kJ/kgK

Calculations:

1. Potential work $=mgz$ in J

2. Amount of heat produced $Q=mC_p(T_2-T_1)$ in J

Conclusion(Importance)ofJoule'sExperiments:

1. Joule's experiment conclusively established that heat is a form of energy.
2. Always the same amount of heat was produced by spending a given amount of mechanical work. It is immaterial what type of arrangement is used for doing mechanical work.
3. It defines the relationship between Joule and Calories.

Practical related questions:

1. What was the outcome of the Joule experiment?
2. What is Joule constant?
3. Why is the mechanical equivalent of heat important?
4. State first law of thermo dynamics.
5. What do you mean by entropy?

