

A LABORATORY MANUAL ON

CAD/ CAM(Pr.3)

6TH SEMESTER (DIPLOMA)

DEPARTMENT OF MECHANICAL ENGINEERING

GOVT. POLYTECHNIC BALASORE



**State Council for Technical Education and Training, Odisha
Near Raj Bhawan, Unit-8 Bhubaneswar-751012 Odisha**

Pr.3 CAD/CAMLAB

Name of the Course: Diploma in Mechanical Engg.			
Course code:		Semester	5th
Total Period:	60	Examination	3Hrs
Theory periods:	4P/W	Sessional:	25
Maximum marks:	75	End Semester Examination:	50

OBJECTIVES

At the end of the course the students will be able to

1. To understand the fundamentals and use of CAD.
2. To conceptualize drafting and modeling in CAD.
3. To interpret the various features in the menu of solid modeling package.
4. To synthesize various parts or component in assembly.
5. To prepare CNC programmes for various jobs

COURSE CONTENTS

PART-A.

INTRODUCTION:

Part modeling, Datum plane, Datum plane; constraint; dimensioning; extrude; revolve; sweep; protrusion; extrusion; rib; shell; hole; round; chamfer; copy; mirror; assembly; align; orient.

EXERCISES:

2D Drawings of Rectangle, circle, polygon and its dimensioning 3D

Drawings of;

1. Gib and cutter joint
2. Screw Jack;
3. Connecting Rod;
4. Bearing Block.

Print the orthographic view from the above assembled 3D drawing

PART-B.

CNC Programming and Machining

INTRODUCTION;

1. Study of CNC lathe, milling;
2. Study of international codes; G-Codes and M Codes
3. Format –Dimensioning methods;
4. Programme writing–Turning Simulator-Milling simulator IS practice-commands menus
5. Editing the programme in the CNC MACHINES;
6. Execute the program in the CNC machines;

Exercise;

1. Print the programme and make the component in the CNC machine;
2. Using canned cycle- create part programme for thread cutting, grooving and produce component in the CNC Turning Machine
3. Using Linear interpolation and Circular Interpolation- Create a part programme for grooving and produce component in the CNC Milling Machine

PART-A.

INTRODUCTION TO AUTO-CAD

- AUTOCAD is a drawing packages of two are developed by the company "AUTODESK" in USA.
- It is one of the widely used software for creating drawing easily.
- Generation of geometric modeling along with the Engineering analyze and devaluate the design and produce drawing for manufacturing with the help of computer.
- The first name of this software is "MICROCAD". Which Is evaluated in 1982.
- Auto Cad Is a command base, non-parametric and low end software. It is the best drawing software.

DEFINITION OF CAD/CAM:

Computer Aided Design– CAD

CAD is technology concerned with using computer systems to assist in the creation, modification, analysis, and optimization of a design. Any computer program that embodies computer graphics and an application program facilitating engineering functions in design process can be classified as CAD software.

The most basic role of CAD is to define the geometry of design– a mechanical part, a product assembly, an architectural structure, an electronic circuit, a building lay out, etc. The greatest benefits of CAD systems are that they can save considerable time and reduce errors caused by otherwise having to redefine the geometry of the design from scratch every time it is needed.

Computer Aided Manufacturing–CAM

CAM technology involves computer systems that plan, manage, and control the manufacturing operations through computer interface with the plant's production resources. One of the most important areas of CAM is numerical control (NC). This is the technique of using programmed instructions to control a machine tool, which cuts ,mills, grinds ,punches or turns raws to ck into a finished part. Another significant CAM functionis in the programming of robots. Process planning is also a target of computer automation.

THE BASIC AUTO-CAD COMMANDS ARE:

A-Arc M-Move B-Block Diagram

O-Offset C- Circle

R-Re draw D-Dimensioning

S-Sketch E-Erase

T-Text F- Fillet

U-previous command G-Grouping

V-View H-Hatching W-Write block I-insert X-explode J-Join Z- Zoom L-Line

EXPERIMENTNO-01

AIM OF THE EXPERIMENT

To create a rectangle by using 2D drafting

THEORY-

A rectangle in a two dimensional plane has 4 corner points which are specified by coordinates. By knowing all coordinates we can construct/create rectangles in a two dimensional plane by using AutoCAD.

APPARATUS/SOFTWARE REREQUIRED-

1. Auto-Desk-2010

LIMIT COMMAND:

- 1) Limits J
- 2) Specify the lower left corner: 0,0J
- 3) Specify the upper right corner: 297, 210J
- 4) ZJ
- 5) AJ

COMMAND FOR LINE:

1. Line/LJ
2. Specify the first point:(,)J
3. Specify the next point:(,)J
4. ESCJ

PROBLEM-3(To draw a rectangle of size-30'x40')

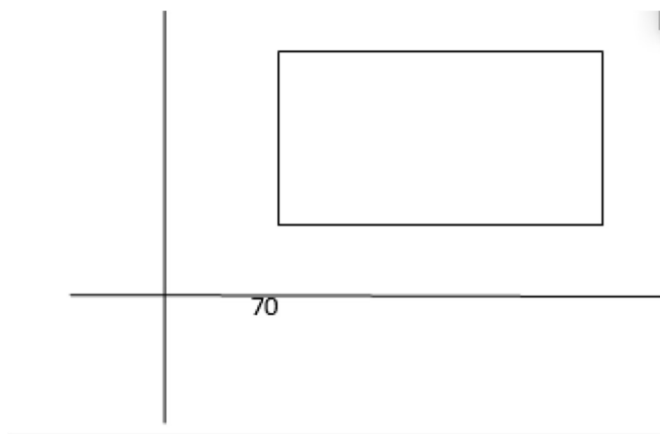

PROCEDURE-80

1. Line J
2. 30,50 J
3. 70,50 J₅₀
4. 70,80 J
5. 30,80 J₃₀
6. 30,50 J

CONCLUSION-

We successfully draw a rectangle by using 2D drafting where the co-ordinates of the rectangles are (30, 50), (70, 50), (70, 80) and (30, 80). One can take other co-ordinates and draw the rectangle also.

EXPERIMENTNO-02

AIM OF THE EXPERIMENT

To draw a circle by using 2D drafting

THEORY-

A Circle in a two dimensional plane has a fixed radius/diameter and its centre has specified by coordinates .By knowing its centre coordinates and radius/diameter we can construct/create Circle in a two dimensional plane by using Auto CAD.

APPARATUS/SOFTWARE REQUIRED-

1.Auto-Desk-2010

COMMANDFORCIRCLE:

- 1) Circle/CJ
- 2) Specify the center of circle J
- 3) Specify the radius or Diameter of the circle J
- 4) Specify the value of R/D of the circle J

PROBLEM:(Create a Circle/draw a circle of ϕ 40)

PROCEDURE-

1. CJ
2. 50,50J
A
3. 20J

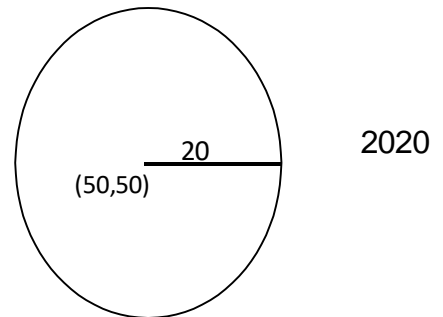

COMMAND FOR 2P(P=Point)CIRCLE:

- 1) Circle/CJ
- 2) Specify the circle center(2P,3P,TTR) J
- 3) 2P)J
- 4) Specify the first point J
- 5) Specify the second point J

PROBLEM: To Create/draw2P Circle of ϕ 60)

1. CJ
2. 2PJ(20,40) (80,40)
3. (20,40)J
4. (80,40)J

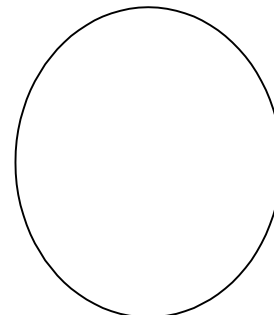

COMMAND FOR 3P (P=Point) CIRCLE:

- 1) Circle/CJ

- 2) Specify the circle center (2P,3P,TTR)J(55,75)
- 3) 3P)J
- 4) Specify the first point J
- 5) Specify the second point J
- 6) Specify the third point J

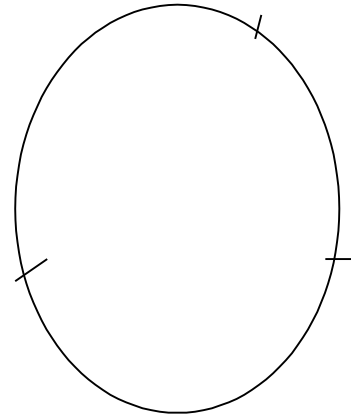

PROBLEM: To Create/draw a 3P circle of ϕ 50(30,50)(80,50)

1. CJ
2. 3PJ
3. (30,50)J
4. (80,50)J
5. (55,75)J

COMMAND FOR TTR (Tangent ,Tangent ,Radius)

- 1) Circle/CJ
- 2) TTRJ
- 3) Specify the first tangent to the circle J
- 4) Specify the second tangent on circle J
- 5) Specify the radius on the circle J

PROBLEM: Draw a Circle TTR (Tangent, Tangent, Radius)

- 1) CJ
- 2) TTR J
- 3) Select the first tangent on the circle J
- 4) Select the second tangent to the circle J
- 5) Radius found J

CONCLUSION-

We successfully draw a Circle by using 2D drafting where...

- i. Radius and coordinate of centre are given.
- ii. Any arbitrary 2 points on the circumference of the circle are given.
- iii. Any arbitrary 3 points on the circumference of the circle are given.

any 2 tangents are given and from it we can find the radius of the circle

EXPERIMENTNO-03

AIM OF THE EXPERIMENT

Draw a Polygon by using 2D drafting.

THEORY-

A Polygon of various no. of sides can be created/drawn if the centres of the polygon and no of sides are specified. We can also inscribe or circumscribe a circle in the polygon in a two dimensional plane by using Auto CAD.

APPARATUS/SOFTWA REREQUIRED-

1.Auto-Desk-2010

COMMAND FOR POLYGON

1. Polygon J
2. Enter no of sides J
3. Specify centre of polygon J
4. Specify in scribed or circumscribed J
5. Specify radius of the circle J

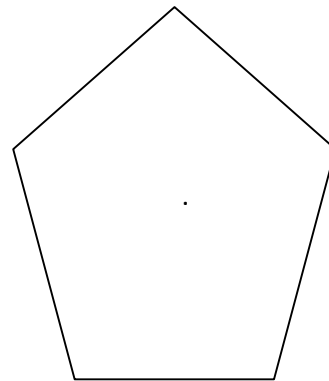

PROBLEM- (To draw a Polygon of any size)

1. Polygon J
2. 5J
3. 50,50J
4. lo rC J
5. 30J

CONCLUSION-

We have successfully drawn a Polygon using 2D drafting where no. of sides is 5 and its centre coordinates (50, 50), having circle of radius 30 inscribed in the polygon.

EXPERIMENTNO-04

AIM OF THE EXPERIMENT

Dimension in garet angle/Circle/Polygon

THEORY-

In this case **corner coordinates of any rectangle, centre coordinates and radius of the circle and no of sides and circle inscribed or circumscribed on a polygon** are given then we can make necessary dimensioning of the side of the rectangle, centre, diameter / radius of a circle and the distance (dimension) of any sides of the polygon in a two dimensional plane by using Auto CAD.

APPARATUS/SOFTWARE REQUIRED-

1. Auto-Desk-2010

COMMAND FOR RECTANGLE

1. Rectangle
2. Specify 1st corner of the rectangle:(,)J
3. Specify the 2nd corner of the rectangle:(,)J
4. Select dimension linear: (,)J_(150,125)

PROBLEM-

1. Rectangle J
2. 50,50J
3. 150,125J_(50,50)
4. Select dimension–Linear J
5. Specify 1st selection line origin J selected
6. Specify 2nd extension line origin J

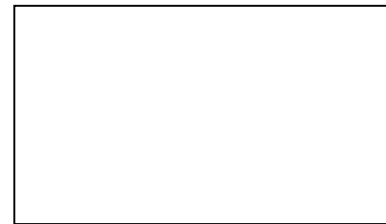

COMMAND FOR CIRCLE:

- 1) Circle/CJ
- 2) Specify the center of circle J
- 3) Specify the radius or Diameter of the circle J
- 4) Specify the value of R/D of the circle J

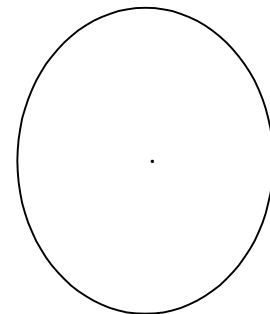

PROBLEM: (Dimension in go for circle)

1. CJ
2. Specify the center and radius J
3. Select the dimension–radius J
4. Select Are cocircle J

COMMAND FOR POLYGON

1. Polygon J
2. Enter no of sides J
3. Specify centre of polygon J
4. Specify in scribed or circumscribed J
5. Specify radius of the circle J

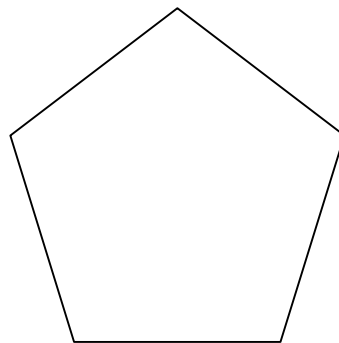

PROBLEM-(To draw a Polygon of any size)

1. Polygon J
2. 5J
3. Specify the centre of the polygon J
4. lo r C J
5. 30J
6. Specify the radius of the circle J
7. Select dimension–Linear J
8. Specify 1stselection line origin J
9. Specify 2ndextension line origin J

CONCLUSION–

We successfully dimension in rectangle, Circle and Polygon.

EXPERIMENTNO-05

AIM OF THE EXPERIMENT

Command sessential for creating 2D drawing

THEORY-

In this case we are required to smoothening out one corner/edge of required radius of curvature by using 2D drawing of a Square/Rectangle. Further we can also draw an exact replica (mirror) of a given figure or an object. Similarly we can make/draw Ellipse and Chamfer of an Object. by using AutoCAD Command.

APPARATUS/SOFTWA REREQUIRED--R-2

1. Auto-Desk-2010

COMMAND FOR FILLET:

- 1) Fillet/FJ
- 2) Radius/RJ
- 3) Specify the radius value J
- 4) Specify or select the first line of the first object J
- 5) Specify or select the second line of the first object J

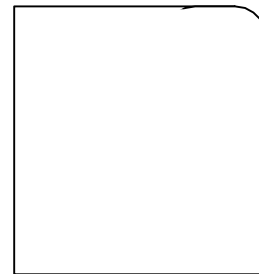

PROBLEM:

Choose/make are rectangular whose one corner is smoothed/Fillet radius2

1. FJ
2. RJ
3. 2J
4. Specify or select the first line of the first object J
5. Specify or select the second line of the first object J

COMMAND FOR MIRROR (rectangle , circleetc):

- 1) Mirror/MIJ
- 2) Select the object J
- 3) Select the first end point to the mirror line J
- 4) Select the second end point of the mirror line J

PROBLEM:(Choose an object)

Make an exact Replica of anObject/Figure.

1. Mirror J

2. Select the object J
3. Select the first and point of the mirror J
4. Select the second and point of the mirror J

COMMANDFORDONUT:

- 1) DONUTJ
- 2) Specify the inside diameter:(,)J
- 3) Specify the outside diameter:(,)J
- 4) Select the position for Donut / Specify the center point of donut J

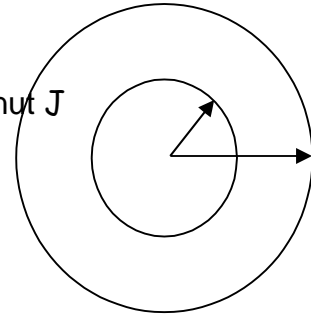

PROBLEM:

1. Do Nut J
2. 40J
3. 60J
4. Select the position for Donut J

COMMAND FOR RECTANGLE:

- 1) Rectangle J
- 2) Specify the first corner of the rectangle:[(0,0)/(x1,y1)]J
- 3) Specify the second corner of the rectangle:[(x2,y2)/(x3,y3)]J
- 4) ESC J

B

PROBLEM:(150,75)

1. Rectangle J
2. (50,50)J
3. (150,75)J
4. EscJ(50,50)



COMMANDFORCHAMFER:

- 1) Cham fer/CHAJ
- 2) Specify the chamfer distance i.e.DJ
- 3) Specify the first chamfer distance(,)J
- 4) Specify these cond chamfer distance(,)J

PROBLEM:

Drawan Rectangle

1. CHAJ
2. 6J
3. 2J

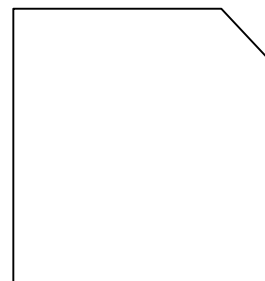

4. 4J

COMMAND FOR ELLIPSE:

- 1) Ellipse J
- 2) Specify the center point of the ellipse(,)J
- 3) Specify the major axis of the ellipse(,)J
- 4) Specify the minor axis of the ellipse(,)J

OR

1. Toll bar>Ellipse>click over ellipse>
2. Define major axis(,) J
3. Define minor axis(,)J

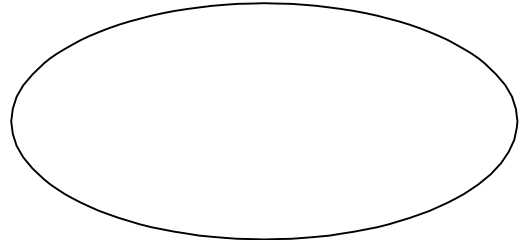

PROBLEM: Drawan Ellipse

1. Ellipse J
2. 50,50J
3. 150,75J
4. 100,25J

COMMAND FOR OFFSET:

1. OJ
2. Specify the off set distance: (,)J
3. Select the line J
4. Choose the side for off setting the line and click hereJ

PROBLEM:

Make an off set for a rectangle

1. OJ
2. 5J
3. Select the line J
4. Choose the side of the off setting J

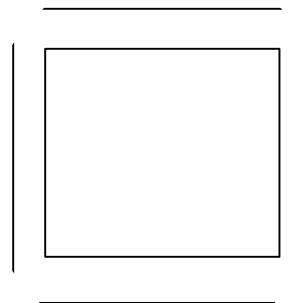

COMMAND FOR HATCHING:

1. Hatch J
2. Click over add: pick a point J
3. Hatch type(Perede fined) J
4. Select pattern of hatch J
5. Preview ,OKJ

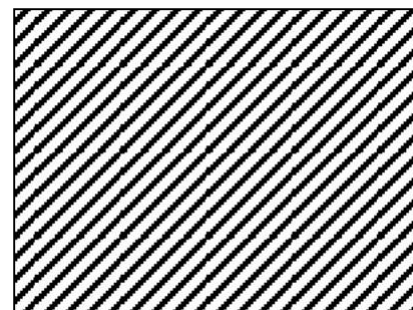

PROBLEM:

1. Hatch J
2. Pick a point J
3. Hatch type (select from table)J
4. Select pattern of hatch J
5. Preview OKJ

COMMAND FOR TEXT:

1. Text J
2. Specify the starting point of the text J
3. Specify the text height J
4. Specify the rotation angle of text J
5. Writing text J

PROBLEM:

1. Text J
2. Specify the starting point of J
3. Specify the text height J
4. Specify the rotation angle of text J
5. Writing text J

COMMAND FOR VERTICAL LINE:

1. XL J
2. VJ
3. Place the vertical line J

PROBLEM:

1. XL J
2. VJ
3. Selected the vertical line J

COMMAND FOR HORIZONTAL LINE:

1. XLJ
2. HJ
3. Place the horizontal line J

PROBLEM:

1. XLJ
2. HJ
3. Selected the horizontal line J



CONCLUSION-

We successfully know the various essential commands for creating 2D drawing.

3-DDRAWINGS

EXERCISE-1

AIM-To develop the part drawing of Gib & Cotter joint in the orthographic representation using AutoCAD.

Description about Gib & Cotter Joint:

When the rods of square or rectangular cross sections subjected to axial forces have to be connected temporarily, a strap joint is used. In this type of cotter joint, the end of one of the rods is formed into a fork into which the end of the other rod fits. The forked end of the rod is called STRAP. Since the strap is open on one side, if only a cotter is used to connect the two rods as explained earlier and when the rods are subjected to axial forces, the end of the strap opens out. To prevent the opening out of the ends of the strap, a gib is used in conjunction with the cotter. The gib is a wedge-shaped piece of steel of rectangular in cross section with one side tapered and the other straight and has two projections, called gib-heads. These gib heads act like hooks and prevent the opening out of the ends of the straps. The use of gib along with the cotter facilitates the cutting of the slots with straight faces.

Procedure:

1. Model different parts of a gib & cotter joint using Extrude, Revolve etc features.
2. Select the assembly in SolidWorks main menu.
3. Using Insert Component no Property Manager, insert base component & next components to be assembled.
4. Assemble using MATE Feature.
5. Continue the inserting the component & mating until the entire component are assembled.
6. Save the assembly.
7. From the main menu of SolidWorks select the drawing option.
8. Drawing icon in main menu of SolidWorks
9. Select the drawing sheet format size as A4 Landscape.
10. Using the model view manager browse the document to be open.
11. Click the view orientate on from the model view manager & place the drawing view in the proper place in the sheet.

12. Using the placed view as parent view project the other or needed views
13. Move course to any one view and right click the mouse button.
14. Select the Table–BOM.
15. Place the BOM in the proper place in the drawing sheet.
16. Save the drawing sheet.

Result:

Thus ,the part drawing of Gib & Cotter joint is drawn north graphic view.

EXERCISE-2

AIM-To develop the part drawing of Screw jack in the or the graphic representation using Auto cad.

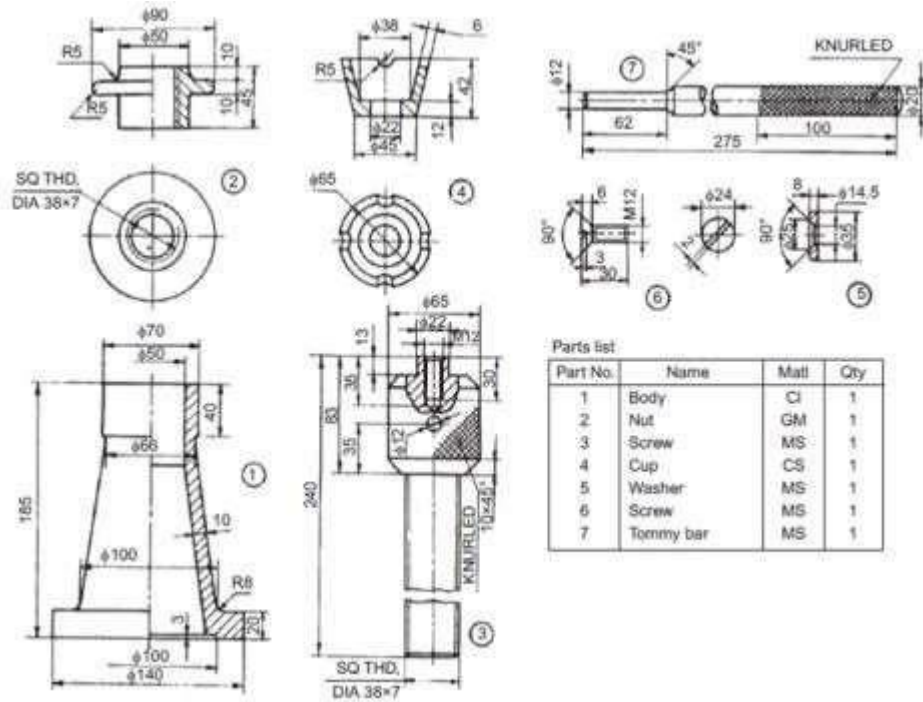

Parts list

Part No.	Name	Matl	Qty
1	Body	CI	1
2	Nut	GM	1
3	Screw	MS	1
4	Cup	CS	1
5	Washer	MS	1
6	Screw	MS	1
7	Tommy bar	MS	1

List of commands:

Line-To draw a line of required dimension.

Circle-To draw a circle of required radius.

Poly line-To draw multiple lines of required dimensions.

Arc-To draw arc of required dimensions.

Trim-To remove unwanted or excess dimensions of the element.

Zoom-To enlarge or reduce the view of component.

Fillet-To join sharp corners with a curve.

Mirror-To reflect the image on other side of the object.

Offset-To draw the mage of the object at required distance.

Erase- To erase any object.

Block- To convert into single entity.

Hatch- Used to hatched closed area.

Join-To joins two objects.

Break- To cut the object to required dimensions.

RESULT: Thus ,the part drawing of screw jack is draw neon the graphic view

EXERCISE-3

AIM – To develop the part drawing of connecting rod in the or the graphic representation.

List of commands:

Line- To draw a line of required dimension.

Circle- To draw a circle of required radius.

Poly line- To draw multiple line so f required dimensions.

Arc- To draw a arc of required dimensions.

Trim- To remove unwanted or excess dimension so f the element.

Zoom- To enlarge or reduce the view of component.

Fillet- To joins harp corners with a curve.

Mirror- To reflect the image on other side of the object.

Offset- To draw the image of the object at required distance.

Erase-To erase any object. **Block-**To convert in to single entity.

Hatch- Used to hatch enclosed area.

Join-To join two objects.

Break-To cut the object to required dimensions.

dimensions.

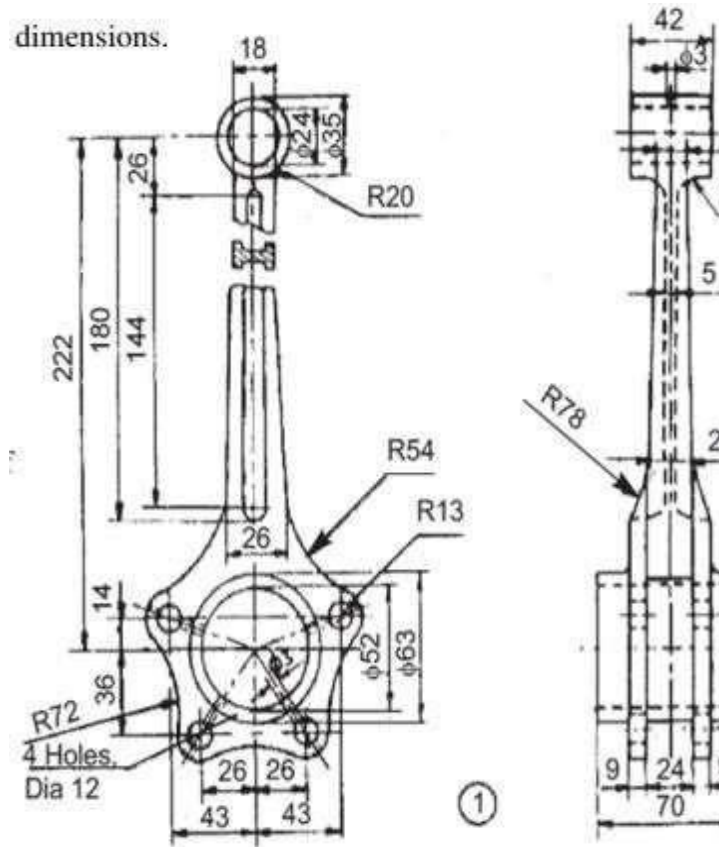

RESULT: Thus, the part drawing of connecting rods drawn in worth graphic view.

EXERCISE-4

AIM- To develop the part drawing of foot step bearing in the orthographic represent at ion using Auto cad.

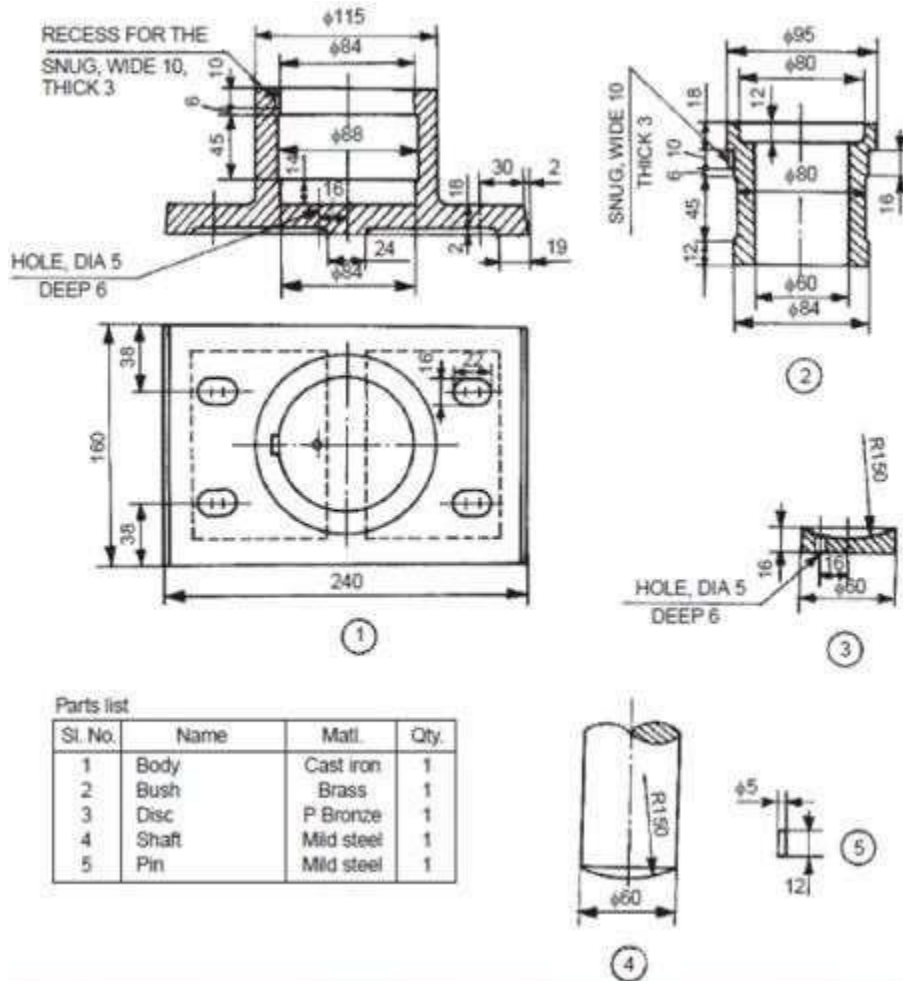

Foot-step bearing

List of commands:

Line- To draw a line of required dimension.

Circle- To draw a circle of required radius.

Poly line- To draw multiple lines of required dimensions.

Arc- To draw arc of required dimensions.

Trim- To remove unwanted or excess dimensions of the element.

Zoom- To enlarge or reduce the view of component.

Fillet- To join sharp corners with a curve.

Mirror- To reflect the image on other side of the object.

Offset To draw the image of the object at required distance.

Erase- To erase any object.

Block-To convert in to single entity.

Hatch- Used to hatched closed area.

Join-To join two objects.

Break- To cut the object to required dimensions.

RESULT: Thus ,the part drawing of foot step bearing is drawn in worth graphic view.

PART-B.CNC Programming and Machining

INTRODUCTION

CNC MILLING/LATHE MACHINE

Numerical control has been developed out of the need for higher productivity, lower cost and more precise manufacturing. This is the latest machine tools control system since the industrial revolution and can be considered as the most sophisticated form of automation for controlling machine tools, equipment or processes.

In NC system, operation instructions are input to the machine as numbers which are suitably coded for storing on tapes. These instructions are then automatically carried out in the machine tool in predetermined sequence with pre-set or self-adjusted speed, feed, etc., without human intervention. Avoidance of human intervention, omission of conventional tooling and featuring an quick-change capability of NC system are the primary factors considered to decide the level of accept ance of CNC machine tools for a particular job .Other maintain able advantage side nti fied of NC machine tools over conventional machine tools with automation are : (i) optimization of cutting tool life and quality of jobs, (ii) possibility of making parts which are impossible in conventional machining systems, and (iii) quick and more accurate inspection and detection of error in design and fabrication.

NC AND ITS COMPONENTS

Numerical control is a technique of automatically facility, based on a code of letters, numbers; an complete set of code instructions , responsible for executing an operation (or set of

operations) called a part program. This program is translated into electrical signals to drive various motors to operate the machine to carry out the required operations.

The components of a traditional NC machine are:

1. **Program of instructions:** The program of instruction, often called part program is the detailed set of directions for producing a component by the NC machine. Each line of instruction is a mixture of alphabetic codes and "numeric data and is punched in a input media (usually paper tape) in a specified format. The input is read by a tape reader which transfers the instructions, to a machine controller to operate the machine slides and to generate specific surfaces on the job.

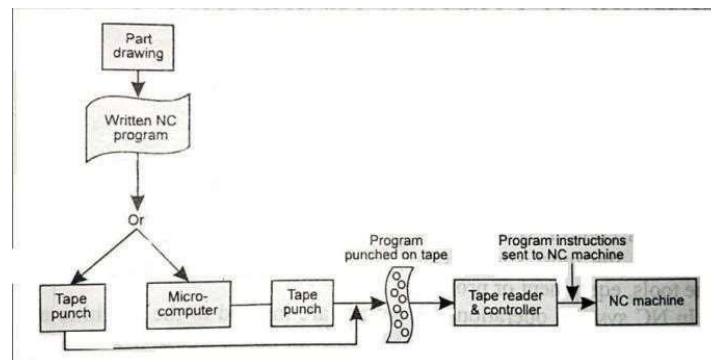

Components of a NC System

2. **Tape punch:** Usually it is a paper tape of 1" width. Paper-Mylar, aluminum Mylar or plastics are also used as tape materials. Paper tapes are cheap and popular but cannot last long. It is treated to resist oil and water. 'Mylar tapes are expensive but durable. Presently tapes are prepared by micro-computers by keying in the information from the manuscript. Once the entire program has been entered, it is checked and corrected if needed, and then the computer activates the tape punching unit to produce the tape. The computer can also generate the program print-out through its printer.
3. **Tape reader :** A tape reader reads the hole pattern on the tape and converts the patterns to a corresponding electrical signal
4. **Machine controller :** Controller receives the electrical signals from tape reader or an operating panel and causes NC machine to respond. It contains a decoder/encoder, an interpolator and facilities to execute auxiliary functions which are machine dependent. The decoder/encoder receives the data and stores them in two separate memory locations. One for the part geometry data and the other for the process data. Process data includes switching functions for adjusting feed rates, spindle speeds, tool changes, cutting fluid applications etc.. Geometric data consists information about tool motions, tool length, tool radius, tool compensation etc.. As the machine is to shape complex surfaces at a constant feed rate, signals must be given to various slides and spindles so that the individual motions can be integrated to produce the required shape which can be represented by complex curve or simple lines. The interpolator breaks down these curves into small individual increments for each controlled motion of the machine tool. Controller also interfaces various machine units like drive motors, transducers and other control functions of the machine tools.
5. **NC machine:** NC machine responds to the electrical signals from the controller. Accordingly the machine executes various slide motions and spindle rotations to manufacture a part. Any NC machine can be considered as a general purpose machine tool fitted with drive motors and other auxiliary functions of the machine. It consists as usual the work table, spindle and other hardwires as a general purpose machine contains. Transducers are fitted to feed back data on the positions of the sideways, for the RPM of the spindle and for the amount of cut on the job. NC machine tools range from single spindle drilling machine to complex machines having multiple motions, tool changers, high capacity tool magazines and multi-axis control.

(The drive units of a NC machine tool mainly consist of stepping motor, DC. motors or hydraulic motors, gear trains and transducers, etc. All these units, taken as a group or series of different elements, are together known as servo controls or servomechanisms. The original commands from MCU are received by the servo controls in the form of electrical signals, or more precisely as electrical pulses, and these are the servo-controls which convert these electrical commands into controlled mechanical movements of various slides and other parts of the machine tool. In case of a closed-loop servo control, it should also essentially contain some sort of a monitoring and feed-back device to ensure that the position of the machine tool slide is truly in conformity with that desired by the MCU.)

CNCLATHE

Lathe is the most productive machine tool to manufacture round parts. Lathes are programmed on two axes: X axis controls the cross motion of the cutting tool and Z axis controls the carriage travel towards and away from the head stock.

A CNC lathe is a computer controlled machinery mainly for **CNC turning services** and process , including tapered turning ,hard turning ,spherical generation ,facing ,parting, knurling, drilling, grooving, etc. These operations can be carried out like conventional lathe machine, while CNC turning lathe is designed to utilize modern technology and tooling to improve the productivity and quality of CNC turning parts.

Benefits of CNC lathes:

- a. Stronger capacity
- b. Higher precision
- c. Improved efficiency
- d. Shorter turnaround time

Components of CNC Lathes

Different types of CNC lathes will different configuration ,but a CNC turning lathe are basically composed of sever allow the following parts :machine bed ,main spindle ,sub-spindle,chuck,guideway,headstock,tailstock,toolturret,monitor,carriage,CNC control eland drive motor. Modern CNC lathe machines often mounted with live tools that can work in multiple axis, like both X and Y-axis ,a second turret with different tools, and more.

WORKING ON A CNC TURNING LATHE :

CNC turning lathe are used to produce precise turned parts with round or cylinder shapes, the finished product is complete, and does not need second operationonotherCNCmachiningequipment.FollowthefollowingprocedureswhileworkingonaCNCIathe

1. Check out whether there is any faults and abnormal situations ,make troubleshooting.
2. Upload the G-Code computer file to the CNC lathe.
3. Install a cylindrical material block and secure dint chuck.
4. Set the spindle at required speed, then to rotate the chuck and work piece.
5. Check the rotating work piece and spindle speed ,ensure there is no discrepancy.
6. Movethetoolturretandcarriagetolocatethecuttingtoolasspecificfeed
7. Move the carriage to perform the cutting operation ,remove all excess materials to get final CNC lathe part.

TYPES OF CNC LATHE MACHINES

As the typical CNC turning machine ,lathes can be classified as different standards.

Based on the number of axes:

- 1) 2-axisCNCLathe:can perform outer /inner diameter machining ,facing ,drilling and tapping.
- 2) 3-axisCNC Lathe :X and Z axis ,C axis and live tool system ,allowed to perform milling, boring, etc.
- 3) 4-axis CNC Lathe: add Y-axis based on 3-axis machine, for off-center machining operation and complex part
- 4) 5-axis CNC Lathe: add a second turrets , allows two tools work at the same time

Based on the work requirements:

- 1) Speed Lathes :simple design ,composed of head stock ,tailstock and tool post, can operate in three and four speeds.
- 2) Engine Lathes :most common lathe machine ,can operate with divers a wide range of speeds, length up to 60 feet.
- 3) Turret Lathes :many different types of tool holders can be mounted on it
- 4) Tool Room Lathes :produce part switch good accuracy and finish

Based on the position of lathe spindle:

- 1) Vertical CNC lathe :the lathe spindle is perpendicular to the horizontal ,with a large diameter circular table used to clamp work piece
- 2) Horizontal CNC lathe :can be divided in to flat guiderail CNC lathe and slant guide way CNC lathe ,the slant guide way structure can make lathe more rigid and easy to discharge chips

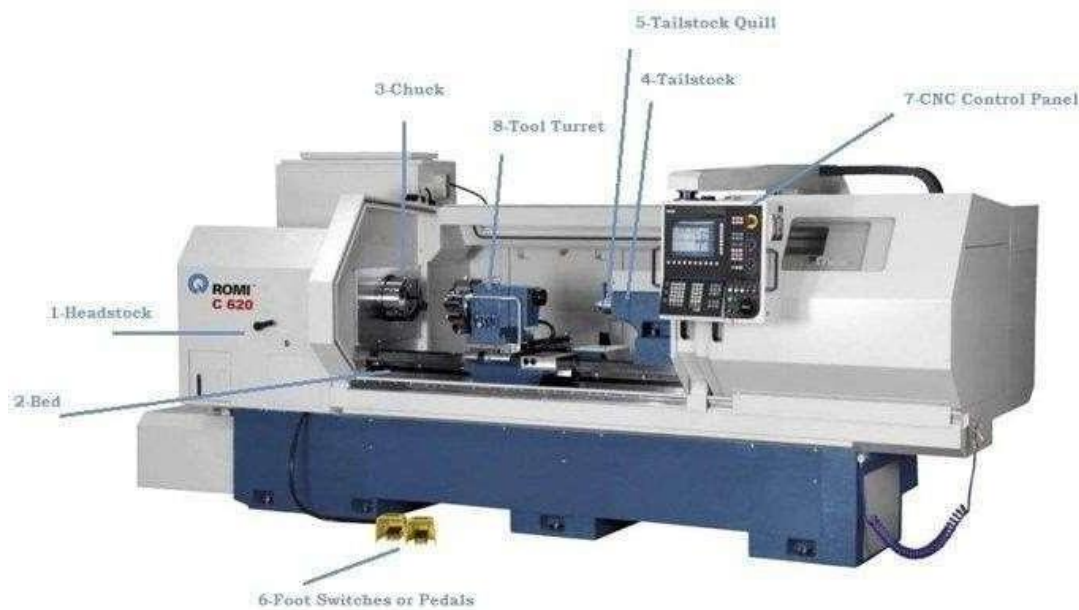

CNC lathe machine

CNCMILLINGMACHINE:

Milling machine has been accepted as one of the most versatile machine tools used in manufacturing industry. Milling machines are programmed on three axes: X axis controls the table movement left or right, Y axis controls the table movement towards and away from the column and Z axis controls the vertical movement of the knee or spindle. CNC Milling Machines are machine operated cutting tools that are programmed and managed by Computer Numerical Control (CNC) systems to accurately remove materials from a work piece. The end result of the machining process is a specific part or product that is created using a Computer Aided Design (CAD) software. These machine tools are normally equipped with a main spindle and three-linear-axes to position or move the part to be machined. More advanced versions may have a

4th or 5th rotational axis to allow for more precise shapes of varying dimensions and sizes to be machined.

CNC milling machines /machining centers normally employ a process of material cutting termed milling or machining – the milling process involves securing a piece of pre-shaped material (also known as the work piece) to a fixture attached to a platform in the milling machine. A rapidly rotating tool(or a series of interchangeable tools) is then applied to the material to remove small chips of the material until the desired shape for the part is achieved. Depending on the material used for the part, as well as the complexity of the machined part, varying axes, cutting head speeds, and feed rates may be applied.

WORKING ON CNC MILLING MACHINE

The general principle for a CNC milling machine or CNC machining center is that the part to be machine is clamped on top of the machine table .It could be clamped directly on the table itself, or held in place by a vice or fixture.

The spindle (moving section) including the cutting tool is then either vertically or horizontally positioned. In that configuration, the tool can reach various X-Y-Z positions on the work piece and commence cutting and shaping actions. As it does so, the work piece or part may either be fixed, mounted, or moved/positioned by the table in a linear direction to the spindle with the cutting tool. This allows material to be removed according to the desired shape needed for the machined part.

COMPONENTS OF A CNC MILLING MACHINE

Frame

The frame is the main structure that supports the milling machine and helps to give it stability and rigidity. It usually comes with a base and detachable column/s. An important part of the frame is the machine headstock where the main spindle is mounted on. The headstock, while important, is often overlooked. If the headstock is not rigid and fails to provide stability and support to the spindle, you could get vibrations and chattering during the machining operation. This could result in machining errors and a shorter lifespan to your cutting tool.

Spindle

The spindle can be considered as the “heart” of a CNC milling machine. It normally comprises a rotating assembly, and a tapered section where tool holders may be positioned. The shaft of the spindle is normally where the tool is attached to, usually via a tool holder. A motor with different levels of transmission is used to rotate the spindle. To keep your spindle in good condition over the long-term, various forms of lubrication are used. They may include Grease Lubrications (not suitable for long durations of high speed operations), Air-Oil Lubrications (sufficient for longer cycle runs at higher speeds) or the Howache on Oil-Jet-Lubrication (ideal for all conditions – even extreme ,long and high speed applications). Depending on the machine type, the spindle can be vertically or horizontally positioned.

Axes

In general, CNC milling machines have X / Y / Z as well as additional rotational axis or C / A or B (subject to configuration). These can be programmed using g-code in the CNC controller.

Column/s

The columns of the CNC machining center can be single, C-Frame or double. This depends on the level of complexity needed in the machining task.

CNC Control Panel

This is the main “nervous system” of the machine tool. It contains the electronics that helps to control the different cutting actions through programming functions. The control panel has a CNC monitor and programming buttons where data and codes can be punched in. It usually also offers a manual function. For ease of machine operation, the control panel should be easily accessible and within easy reach.

Tool/Tool Changers(Automatic Tool Changer Or ATC)

These are either mounted at the column or separately mounted to the machine. The latter is preferred if larger tool changers are needed with 40 up to 300 different tools. Doing so not only helps to save time and effort – it also helps your operators to avoid unnecessary vibrations during operation.

Tool Holders

These come in many different sizes, systems and for various applications. The standard sizes for tool holders are BT 30 to BT 40 and BT 50 (BT refers to the taper angle of the cone on the holder).

(In Europe, the term used is SK30, SK40 or SK50, which has the same angle as B Holder but with an additional orientation groove at the flange. Together with a key-stone mounted at spindle nose, SK holders can be orientated in a specific position. Eg.: boring bridges, boring bars, angular milling heads etc.)

For higher rigidity and balanced fast rotations, BBT versions are recommended or the HSK System.

Table

The table provides a solid base to clamp the work piece directly on, and can be used to mount fixtures or vice to hold the piece in place. Most of the tables use T-slots for easy clamping of vice, fixture or part.

On Horizontal CNC milling machines, pallets are also available with Tap-holes. These allow greater flexibility in moving different work pieces to be machined. Increasingly, magnets are also being used for easy, fast and secured clamping. These should preferably be built into the machines table to avoid the loss of Z-axis height.

Coolant Tank

Most CNC machining centers have a coolant tank to help supply coolant to the cutting surface or the spindle with tool during machining action. This helps to lengthen the life-span of the machine and its parts. Beyond this, the coolant will also remove heat generated by the machining action, and hence keep temperatures under control.

TYPES OF MILLING MACHINE

Here are some of the types that you may find in the market:

- a. Horizontal Milling Machines
- b. Vertical Milling Machines
- c. Bed Mill
- d. Turret Mill (for manual machine only)
- e. Travelling Column
- f. Double Column
- g. C-Frame

- h. Drill & Tap
- i. Five Axis Machining Centers
- j. Double Spindle

In general, CNC milling machines can deploy a wide range of cutting and shaping tools. These tools help to remove material by virtue of how they move within the machine or directly from the cutter's shape. These may include the following:

- i. End Mills, Flat or Ball nose ,Straight or Form Tools.
- ii. Face Mills
- iii. Drills ,U-Drills, Spiral Borer.
- iv. Taps
- v. Reamers
- vi. Tool Holders and Hydraulic Tool Holders, Shrink-Fit or Press-Fit holders.



CNC milling machine

Study of international codes ;G-Codes and M-Codes

G-codes, also called preparatory codes, are any word in a CNC program that begins with the letter G. Generally it is a code telling the machine tool what type of action to perform, such as:

- Rapid movement (transport the tool as quickly as possible in between cuts)
- Controlled feed in a straight line or arc
- Series of controlled feed movements that would result in a hole being bored, a work piece cut (routed)to a specific dimension, or a profile (contour)shape added to the edge of a work piece
- Set too line formation such as offset
- Switch coordinate systems

G Codes for CNC Milling

- G00:RapidMotion

- G01:LinearInterpolationMotion
- G02:CWInterpolationMotion
- G03:CCWInterpolationMotion
- G04:Dwell
- G09:ExactStop
- G10:ProgrammableOffsetSetting
- G12:CW Circular Pock Milling(Y as n ac)
- G13:CCWCircularPockMilling(Y as n ac)
- G17:XYPlane Selection

M-code controls **miscellaneous functions**, and typically these can be thought of as non-geometry **machine functions**. Examples include spindle rotation start and stop, coolant on and off, pallet change, etc. Some of these functions may vary by the **specific machine**. Similar to G-code, M-code consists of a “**M**” and a number. Unlike G-code, however, M-code can be more specific for different machines and is more **customizable**. Both types are needed to have a CNC machine perform its functions. Like any language, CNC has many other aspects to it. This chart is just a sampling of all the **program lines** that could be included in the code.

M Codes for CNC Milling

- M00:Program Stop
- M01:OptionalProgramStop
- M02:Program End(Setting39)
- M03:SpindleOn,Clock wise(S)(Setting144)
- M04:Spindle On, Counter clock wise(S)(Setting144)
- M05:Spindle Stop

- M06:ToolChange(T)(Setting42,87, 155)
- M08:CoolantOn(Setting32)
- M09:CoolantOff
- M10:4thAxisBrakeOn

(5) **Editing the programme in the CNC MACHINES**

Edit mode is very important in CNC. This mode is used to enter and store programs in a CNC machine. If you want to copy, cut, delete a program, you can do it in this mode. Also, this mode is used to replace any code or command in the program.

Insert a new program in to the system

Step1– Press “EDIT ” key.

Step2–ON“PROGRAM PROTECT”.

Step3- Press “PROG ”key.

Step4–Write new program number which is start from alphabetO

Like: **O0123**

Press INSERT ”key.(new window opens)

Press “EOB” key. (for complete block)

Press “ INSERT” key.

Step5 –write the program

(1.If anything wrong while writing then uses “CAN” key to cancel.

2. If wrong command or code insert in a block then cursor on these and press “DELETE” key.)

[Note: Program store automatically in system]

Program COPY ,CUT and PASTE

Step3—Press “PROG ”key. Select the program you want to copy.

Step4—Press soft key “LEFT-HANDAR ROW ”button .Pressing this key will bring up the “SELECT” option at the bottom of the screen. Then

Press “soft key just below the SELECToption“

Step5-After that ,you have to select the program you want to copy.To select Press “CURSOR DOWN” key.

Step 6 – Then the bottom of the screen there is COPY, CUT option. Depending on your convenience, you can use a copy for copy OR cut for delete. But here we have to select the copy.

Press “soft key just below the COPY”

Step 7 - To paste the copied program, type the program no. of the program you want to paste in .ex. we want to paste in Prog NO. O0123

Type program no.(O0123)in the system then

Press “ INSERT” key.

Step8—Set cursor position where you want to paste.

Step9—Then the bottom of the screen there is PASTE option.

Press“ soft key just below the PASTE”.

For Replace code or command

Step4—Select code or command which is want to replace.
Ex .Here we want to change T0202 take cursor on this command.
And want to replace with T0101.

Step5–Type“T0101”.

Step6–Press“ALTER”key.

Deleted total program

Step4–Select cursor on Program no.here we select program no O0123 in following image.

Step5– Press“DELETE”key.

Step6–After press delete key then machine asks confirmation the message will show in the screen as below image. There is two option

CAN (Cancel for delete on process)

EXEC (Execute for delete ion process)

Step7– Press“ soft key just below EXEC”.

Execute the programme in the CNC machines

1. Start the CNC program
2. Load the required tool.
3. Turn the coolant on.
4. Turn the spindle on.
5. Move to a position above a part.
6. Start the machining process.
7. Turn the coolant off.
8. Turn the spindle off.
9. Move away from the part to a safe location.
- 10.End the CNC program.



PROGRAMMING VARIOUS OPERATIONS IN VERTICAL CNC MILLING MACHINE

Print the program mean make the component in the CNC machine

```
N 10 ("DIA_50.0MMFACEMILLCUTTECR)
N20G0 G17G64 G71 G94 G90
N30G75 Z0.0
N40G75X0.0Y0.0 N50T06M6
N60D1
N70M03S900
N80 F300
N90G0G40G56X150Y-35 N100
G0 Z50
N110 G0 Z1.0
N120G01Z0.0
N130 G01 X-95.0Y-35.0
N140 G01 X-95.00 Y0.0
N150 G01 X95.00 Y0.0
N160 G01 X95.0 Y35.0
N170G01X-150.0Y35.0
N180 G0 Z50.0
N190G0X150.0Y-35.0
N200 G0 Z1.0
N210 G01 Z0.0
N220G01Z-0.05
N230 G01 X-95.0Y-35.0
N240 G01 X-95.00 Y0.0
N250 G01 X95.00 Y0.0
N260 G01 X95.0 Y35.0
N270G01X-150.0Y35.0
N280 G0 Z50.0
N290 G75 Z0.0
N300G75X0.0Y0.0
N310 M05
N320M09
N330M01
```

```
N10MSG("DIA50.0MMFACEMILLCUTTECR,2) N20G0
G17G64 G71 G94 G90
N30G75 Z0.0
N40G75X0.0Y0.0 N50T06M6
N60D1
N70M03S900
N80 F300
N90G0G40G56X150Y-35 N100
G0 Z50
```

N110 G0 Z1.0
N120G01Z0.0
N130 G01 X-95.0Y-35.0
N140 G01 X-95.00 Y0.0
N150 G01 X95.00 Y0.0
N160 G01 X95.0 Y35.0
N170G01X-150.0Y35.0
N180 G0 Z50.0
N190G0X150.0Y-35.0
N200 G0 Z1.0
N210 G01 Z0.0
N220G01Z-0.05
N230 G01 X-95.0Y-35.0
N240 G01 X-95.00 Y0.0
N250 G01 X95.00 Y0.0
N260 G01 X95.0 Y35.0
N270G01X-150.0Y35.0
N280 G0 Z50.0
N290 G75 Z0.0
N300G75X0.0Y0.0
N310 M05
N320M09
N330M01

(PROGRAMMING FOR DRILLING OPERATION)

N360G0G17G64G71G94G90 N370
G75 Z0.0
N380G75X0.0Y0.0
N390 T05M6
N400D1N410M0
3S900 N420
F200 N430
M08
N440G0G40G56X75Y-20.0 N450
G0 Z50
N460 G0 Z1.0
N470 G01 Z0.0
N480 G01 Z-1.5
N490 G01 Z0.0
N500 G01 Z-5.0
N510 G01 Z-2.0
N520G01Z-10.0
N530G01Z0.0F200
N540 G00 Z50
N550G0G40G56X75Y20.0 N560
G0 Z50
N570 G0 Z1.0
N580 G01 Z0.0
N590 G01 Z-1.5
N600 G01 Z0.0
N610 G01 Z-5.0
N620 G01 Z-2.0
N630G01Z-10.0
N640G01Z0.0F200

N650G0Z50
N660G0G40G56X-75Y-20.0
N670 G0 Z50
N680 G0 Z1.0
N690 G01 Z0.0
N700 G01 Z-1.5
N710 G01 Z0.0
N720 G01 Z-5.0
N730 G01 Z-2.0
N740G01Z-10.0
N750G01Z0.0F200
N760 G0 Z50
N770G0G40G56X-75Y20.0 N780
G0 Z50
N790 G0 Z1.0
N800 G01 Z0.0
N810 G01 Z-1.5
N820 G01 Z0.0
N830 G01 Z-5.0
N840 G01 Z-2.0
N850G01Z-10.0
N860G01Z0.0F200
N870 G0 Z50
N880G75Z0.0
N890G75X0.0Y0.0
N900 M09
N910M05
N920M01
N930

N940 (MILLINGWITHCIRCULARINTERPOLATION)

N950G64G71G94G90 N960
G75 Z0.0
N970G75X0.0Y0.0
N980 T02M6
N990 D1
N1000G0G90G56X95.Y-40.S2000M3 N1010
G0 Z50.
N1020Z10.N1030G1
Z-.2F50. N1040X-
95.F700.
N1050G2X-100.0Y-35.CR=5.
N1060 G1Y35.
N1070G2X-95.Y40.CR=5.
N1080 G1X95.
N1090G2X100.Y35.CR=5.
N1100 G1Y-35.
N1110G2X95.Y-40.CR=5.
N1120 G1Z-.4F50.
N1130X-95.F700.
N1140G2X-100.Y-35.CR=5.
N1150 G1Y35.
N1160G2X-95.Y40.CR=5.
N1170 G1X95.

N1180G2X100.Y35.CR=5.
N1190 G1Y-35.
N1200G2X95.Y-40.CR=5.
N1210 G1Z-.6F50.
N1220X-95.F700.
N1230G2X-100.Y-35.CR=5.
N1240 G1Y35.
N1250G2X-95.Y40.CR=5.
N1260 G1X95.
N1270G2X100.Y35.CR=5.
N1280 G1Y-35.
N1290G2X95.Y-40.CR=5.
N1300 G1Z-.8F50.
N1310X-95.F700.
N1320G2X-100.Y-35.CR=5.
N1330 G1Y35.
N1340G2X-95.Y40.CR=5.
N1350 G1X95.
N1360G2X100.Y35.CR=5.
N1370 G1Y-35.
N1380G2X95.Y-40.CR=5.
N1390 G1Z-1.F50.
N1400X-95.F700.
N1410G2X-100.Y-35.CR=5.
N1420 G1Y35.
N1430G2X-95.Y40.CR=5.
N1440 G1X95.
N1450G2X100.Y35.CR=5.
N1460 G1Y-35.
N1470G2X95.Y-40.CR=5.
N1480 G1Z-1.2F50.
N1490X-95.F700.
N1500G2X-100.Y-35.CR=5.
N1510 G1Y35.
N1520G2X-95.Y40.CR=5.
N1530 G1X95.
N1540G2X100.Y35.CR=5.
N1550 G1Y-35.
N1560G2X95.Y-40.CR=5.
N1570 G1Z-1.4F50.
N1580X-95.F700.
N1590G2X-100.Y-35.CR=5.
N1600 G1Y35.
N1610G2X-95.Y40.CR=5.
N1620 G1X95.
N1630G2X100.Y35.CR=5.
N1640 G1Y-35.
N1650G2X95.Y-40.CR=5.
N1660 G1Z-1.6F50.
N1670X-95.F700.
N1680G2X-100.Y-35.CR=5.
N1690 G1Y35.
N1700G2X-95.Y40.CR=5.
N1710 G1X95.

N1720G2X100.Y35.CR=5.
N1730 G1Y-35.
N1740G2X95.Y-40.CR=5.
N1750 G1Z-1.8F50.
N1760X-95.F700.
N1770G2X-100.Y-35.CR=5.
N1780 G1Y35.
N1790G2X-95.Y40.CR=5.
N1800 G1X95.
N1810G2X100.Y35.CR=5.
N1820 G1Y-35.
N1830G2X95.Y-40.CR=5.
N1840 G1Z-2.F50.
N1850X-95.F700.
N1860G2X-100.Y-35.CR=5.
N1870 G1Y35.
N1880G2X-95.Y40.CR=5.
N1890 G1X95.
N1900G2X100.Y35.CR=5.
N1910 G1Y-35.
N1920G2X95.Y-40.CR=5.
N1930 G0Z50.
N1940M5
N1950G75Z0.0
N1960G75X0.0Y0.0 N1970
M01

Using linear interpolation and Circular Interpolation-Create a part program for grooving and produce component in the CNC Milling Machine.

N870G0G90G64G40;MILLINGWITHCIRCULARINTERPOLATION-2 N880
G75X0Y0
N890T04M06
N900G0G55X-125Y15M03S1200
N910 G0Z50.M08
N920G01Z10.F1000
N930 G01Z0.F500
N940G01X125.F160
N950 Y-15.
N960 X-125.
N970G0Z100.M09
N980 G75X0Y0
N990 G75Z0.
N1000M05
N1010M01
N1340G0G90G64G40
N1350 G75X0Y0
N1360 T03M06
N1370G0G57X0Y0M03S2500
N1380 G0Z50.M08
N1390 G01Z10.F1000
N1400 G01Z-.5F150
N1410 G01X170F300
N1420G03X180Y10CR=10

N1430 G01Y50
N1440G01X170Y60
N1450 G01X5
N1460G03X0Y55CR=5
N1470 G01Y0
N1480G01X-30Y-30
N1490 G0Z100
N1500 G75X0Y0Z0
N1510 M01
N1520M30

PROGRAMMINGFORSLOTING/GROOVING

N10G0G90G64G40
N20G75X0Y0N30
T07M06
N40 D1
N50M06
N60G0G55X0Y0M03S2000
N70 G0Z50.M08
N80G0X-85Y-50
N90 G0Z5.
N100G01Z-.5F300
N110 G01Y50.
N120 Z-1.
N130 Y-50.
N140 Z-1.5
N150 Y50.
N160 Z-2
N170 Y-50
N180 Z-2.5
N190 Y50
N200 Z-3
N210 Y-50
N220 Z-3.5
N230 Y50
N240 Z-4
N250 Y-50
N260 Z-4.5
N270 Y50
N280 Z-5
N290 Y-50
N300G0Z5M09
N310G0Z100M05
N320G75X0Y0Z0
N330 M01
N340 M30